



Installation Instructions

2007-2008 Toyota Tundra

(Mounting Bracket# 4420 / Mounting Kit #4421)



IMPORTANT!

1. The SuperGlide's Way tubes are coated with SlipPlate® at the factory to provide lubrication for ONE TRIP ONLY. You must inform the customer that he will need to continue using the graphite-based lubricant SlipPlate® or a medium duty grease on the top and inward facing sides of the way tubes.
2. **The trailer's king pin box must be equipped with a Capture Plate (Universal or Quick Connect) to allow the hitch to function (must be purchased separately).**
3. Consult the maintenance section of the SuperGlide Owners Manual for complete Instructions. **Failure to lubricate the Way Tubes will cause galling between the Way Tubes and the Cam Arm assembly resulting in failure of the hitch to work properly.** Destruction of various hitch parts is likely and will not be covered under the Manufacturer's Warranty.
4. Failure to modify the length of the brake cable may cause the cable to catch on protruding parts of the hitch. Resulting damage will not be covered by the manufacturers warranty.
5. There should be a minimum of 6" between the truck bed rails and the under side of the trailer for side tilt clearance. It is the customers responsibility to adjust the trailer king pin box for the appropriate amount of clearance.
6. It is the installer and customer's responsibility to ensure there is proper clearance between the truck and trailer. There should be a minimum of 2" clearance as the trailer passes the cab. Call PullRite technical support with trailer width, make and year of truck, and distance the king pin is from the leading edge of the trailer (See "Dimension A" under "Caution," Figure 1 on Page 3 of the SuperGlide Owners Manual) at (800) 443-2307.
7. Read these instructions completely and follow them accurately. Should you have any questions, please call the factory at (800) 443-2307 prior to installation for assistance.

Table of Contents

Universal Capture Plate Installation	3-4
Template and Truck Bed Layout Method	5
Mounting Bracket Install Instructions	6-7
Installation Photos #1 & #2	8
Installation Photos #3	9
2007-2008 Toyota Tundra Assembly – Exploded View	10
Parts List	11

UNIVERSAL CAPTURE PLATE INSTALLATION

The following instructions should be followed to install the Universal Capture Plate. Note: If more information is needed, please call PullRite at (800) 443-2307.

NOTE: Quick Connect Capture Plates are available for various king pin box sizes. Contact the Customer Service Dept. at PullRite for further assistance.

NOTE: 10 bolts are required to fasten the Universal Capture Plate. Make certain they are positioned so the front row of holes have at least 2 to 3 fasteners, the rear row of holes has 2 fasteners and each outside row of holes has 2 to 3 as well. Fill in around the king pin. If you are not able to bolt into the outside perimeter, you will need to weld on extensions to the king pin plate, both front and rear. See instructions for "King Pin Boxes That Are Shorter Front to Back."

I. FOR KING PIN BOXES WITH A FLANGE: (Figure 3)

1. Place the Capture Plate over the king pin, with the guide wedge towards the rear of the trailer (wedge facing down). Align the Capture Plate square with the king pin box and clamp in place to prevent movement.
2. Mark the holes for drilling through the Capture Plate onto the king pin box flange.
3. Remove the Capture Plate or use it as a guide and drill 1/4" holes through the flange.
4. Re-install the Capture Plate (as in step 1).
5. Use the 1/4" bolts provided, to secure the Capture Plate onto the king pin box flange. A **minimum of 10 bolts** must be used to fasten the plate on. These fasteners do not count as part of the minimum number of bolts required. Make certain all the bolts are **flush with the trailer plate**. Fasteners that are installed at an angle catch and "drag" on the 5th wheel plate surface, weakening the integrity of the fastener.
6. If the Capture Plate extends beyond the king pin box, then install the braces {K2-K4} as shown in Figure 4. These fasteners do not count as part of the minimum number of bolts required.

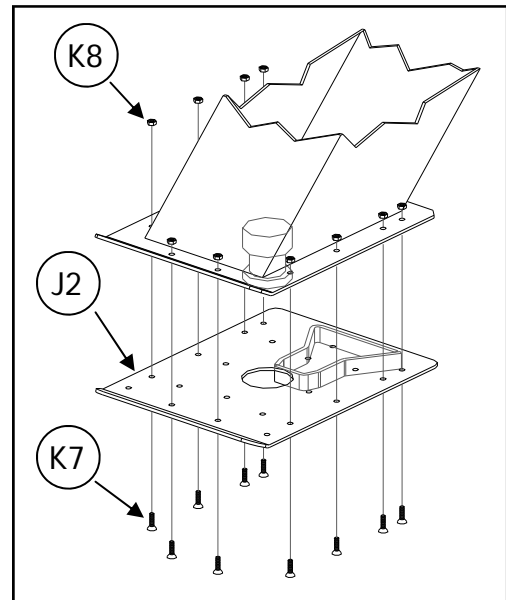

Figure 3

II. FOR KING PIN BOXES WITHOUT FLANGES: (Figure 4)

1. Place the Capture Plate {J2} over the king pin, with the guide wedge towards the rear of the trailer (wedge facing down), and hold in place to prevent movement.
2. The Capture Plate can be secured to the king pin box sides by welding angle iron supports to the king pin box, or use the extension plate in Section III on the following page. (Angle iron is not provided).
3. For the holes where you cannot reach the inside nose of the king pin box, drill holes with a #8 drill and tap with a 1/4"-20 tap.
4. If the Capture Plate extends beyond the king pin box, then install the knee braces as shown in Figure 4.
5. Use the 1/4" bolts provided, to secure the Capture Plate onto the king pin box flange. A **minimum of 10 bolts** must be used to fasten the plate on. These fasteners do not count as part of the minimum number of bolts required. Make certain all the bolts are **flush with the trailer plate**. Fasteners that are installed at an angle catch and "drag" on the 5th wheel plate surface, weakening the integrity of the fastener.

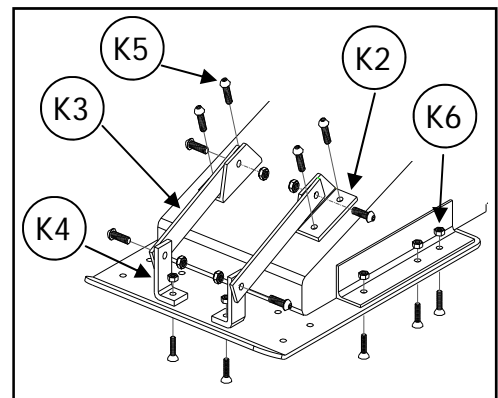

Figure 4

UNIVERSAL CAPTURE PLATE INSTALLATION (cont.)

III. FOR KING PIN BOXES THAT ARE SHORTER FRONT TO BACK:

1. Place the Capture Plate over the king pin, with the guide wedge towards the rear of the trailer (wedge facing down), and measure the distance from the front and rear of the king pin box to the respective edges of the Capture Plate (to the bend of the Capture Plate in the front). Referring to Figure 5, using the supplied extension plates, fasten plates to the front and back row of holes using the 1/4" bolts and lock nuts provided.

CAUTION: The provided extension plates are universal and must be trimmed to fit your specific application. When extensions are installed, the capture plate adapter (#3317) should be flush against the bottom of the trailer's king pin plate.

2. While the trailer plate is in position under the king pin box, clamp these plates to both the front and rear of the Capture Plate. Remove the Capture Plate and drill matching holes in the two support plates with a 1/4" bit using the Capture Plate as a guide.
3. Fasten the two support plates to the Capture Plate with the 1/4" Bolts {K7} and Lock Nuts {K8} provided.
4. Replace the Capture Plate on the king pin box, check for square alignment and weld the extension plates to the king pin box.
5. Attach the Knee Braces {K2,3 & 4} to the king pin box and the Capture Plate. Braces {K2} may have to be welded on if the interior of the king pin box is not accessible.
6. See Figure 5 below for diagram and special notes.

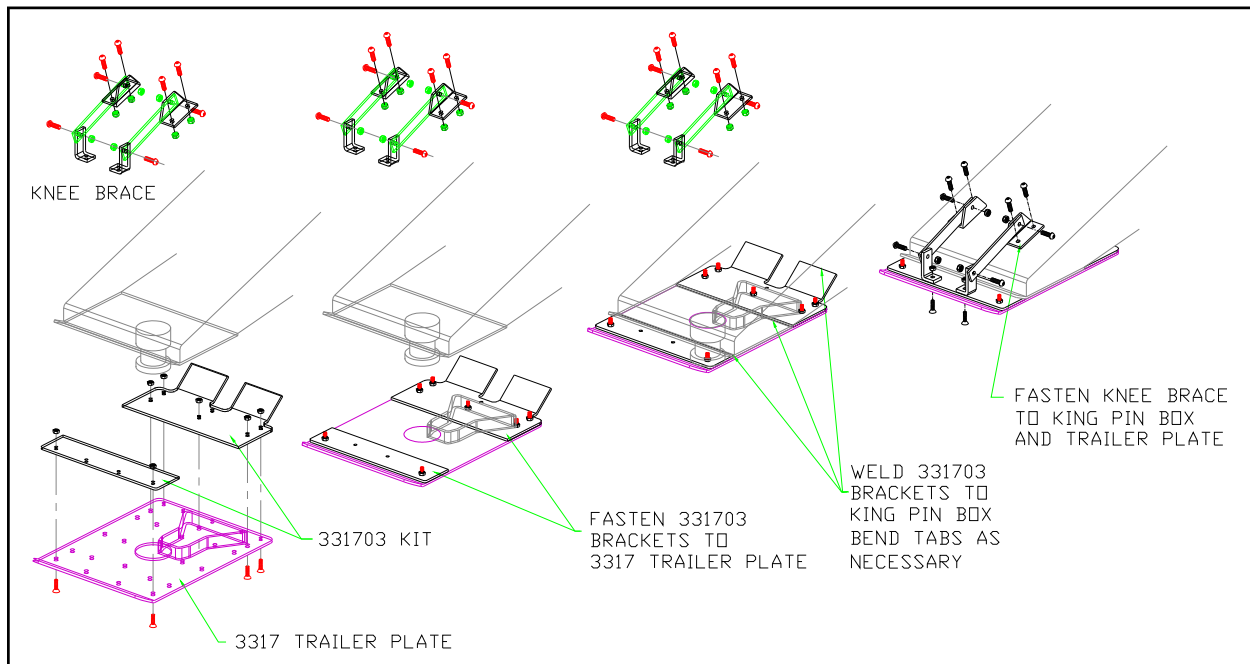
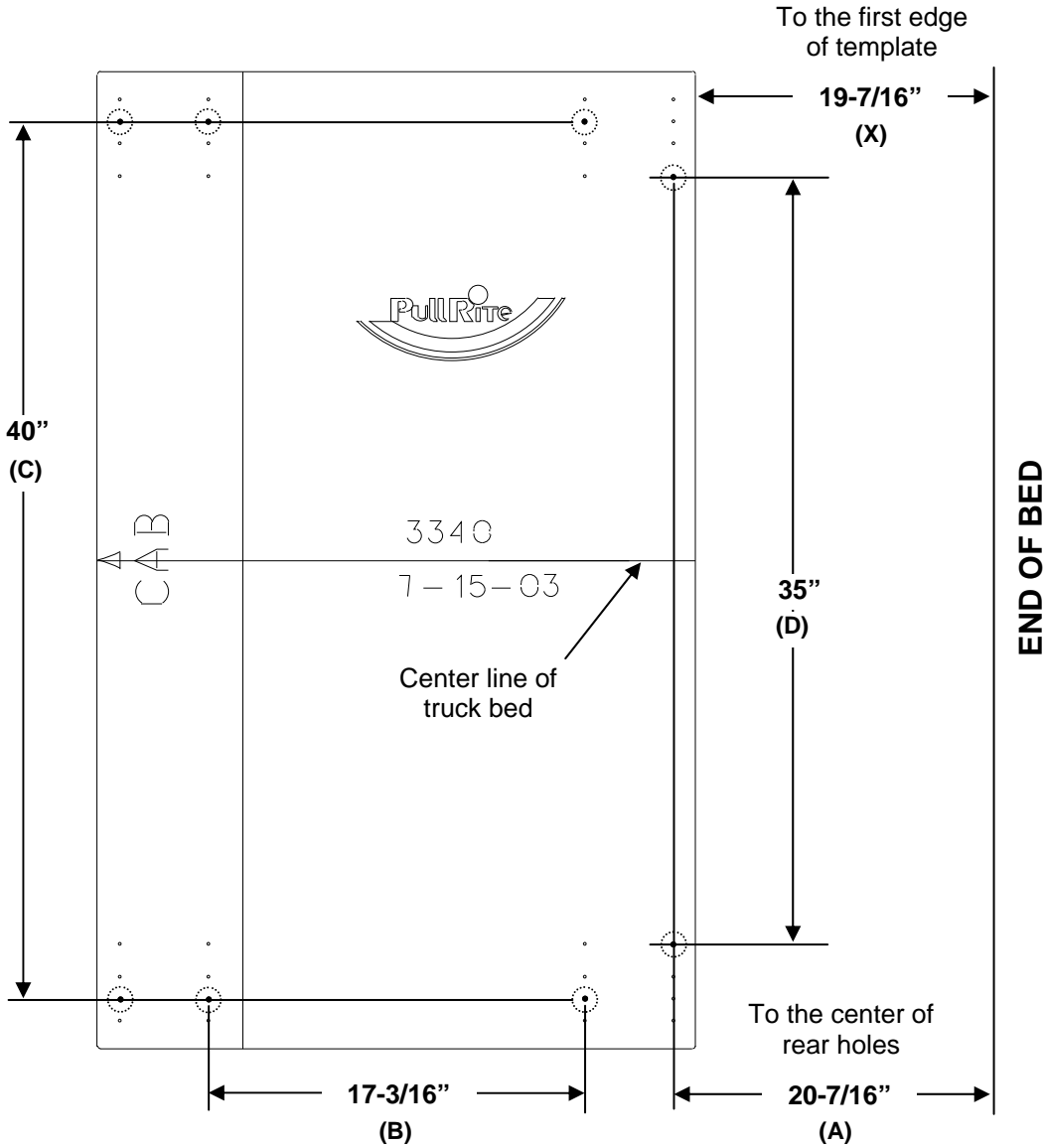

Figure 5

Template Method



INSTALLATION TIP:

The template has a tendency to move when placed on the slick paint of new truck beds, and it may be helpful to place a small piece of NON-SKID matting, such as "SCOOT-GARD"™, to help keep the template from moving.

Layout Method

Truck Bed Dimension Table

Layout Method				Template Method	
"A"	"B"	"C"	"D"	"X"	Template Part #
20-7/16"	17-3/16"	40"	35"	19-7/16"	33400000

MOUNTING BRACKET INSTALLATION INSTRUCTIONS

1. Verify the part numbers listed on the shipping carton and check part quantities using the Parts List on page 11.
2. Remove the spare tire.
3. Layout the bed according to the layout or template method drawing on the previous page, marking each hole carefully.
4. Cover each slotted hole on the top flange of each mounting bracket with transparent tape.
5. On the rear driver side, remove and retain the front bolts on the factory hitch receiver bracket. See Installation Photo #3 on page 9.

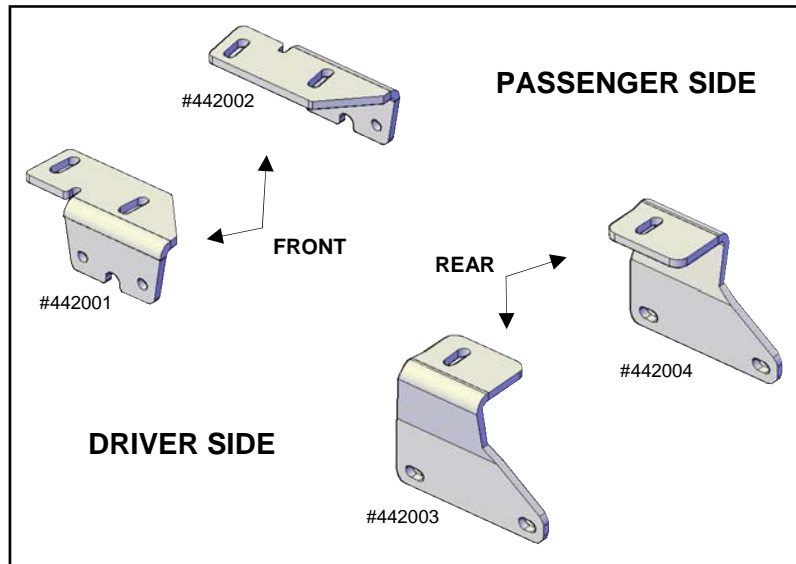

Bracket Identification

6. Slide the rear driver side bracket (#442003) between the frame and the factory hitch receiver bracket.
7. On the rear passenger side, remove the front two bolts on the factory hitch receiver bracket, and loosen the rear bolts to allow the mounting bracket (#442004) to slide more easily past the shock tower.
8. Loosely reinstall the factory bolts removed on Steps 4 and 6.

CAUTION: Fuel pump is located below the front driver side mounting bracket. Use extreme caution or simply remove the fuel pump prior to drilling the bed and frame holes.

8. Clamp the front brackets to the frame. Position as seen in the figure on Page 7 and on Installation Photos 1 and 2 on Page 8.
9. Using the **marked** holes in the Bed Layout as a guide, drill a 1/16" hole through the bed beginning with the driver side front holes.
10. When the pilot hole is drilled through the bed, the transparent tape will be pierced by the small drill. It should be centered front-to-back of the bracket's slotted hole.
11. Drill each of the marked hole locations, preferably using a step drill of at least 3/4" diameter. (A step drill is a cone shaped bit that has a variety of gradually larger diameter sizes the deeper the drill is used). The 3/4" holes will be covered by the Base Rails and will make the installation easier than if a 1/2" hole is used.

MOUNTING BRACKET INSTALLATION INSTRUCTIONS (CONT.)

12. Place the hitch, with the Base Rails attached, over the top of the drilled holes after removing the drill shavings from the bed and treating the holes with a suitable rust inhibitor.
13. Insert a 1/2"-13 x 2" Hex Bolt through each bed hole.
14. Fasten the Base Rails and Mounting Brackets to the bed using Bed Shims to fill the bed channel (Bed Shims keep the bed channels from collapsing when the bolts are tightened), Flat Washers and Flange Nuts. (See Page 10 for placement of Bed Shims).
15. Fasten the Base Rails to the bed using the four Offset Hole Back Up Plates. (See Page 10).
16. Tighten all Base Rail / Bed bolts to 75 foot pounds.

NOTE: Before drilling, check the inside of the frame to guard against drilling into the fuel tank, wiring, brake lines or fuel module.

17. Drill 1/2" holes in the frame for each Front Mounting Bracket using the pre-punched holes in the mounting bracket as a guide and insert the 1/2" Frame Bolts to fasten.
18. Tighten the Mounting Brackets to 75 foot pounds.

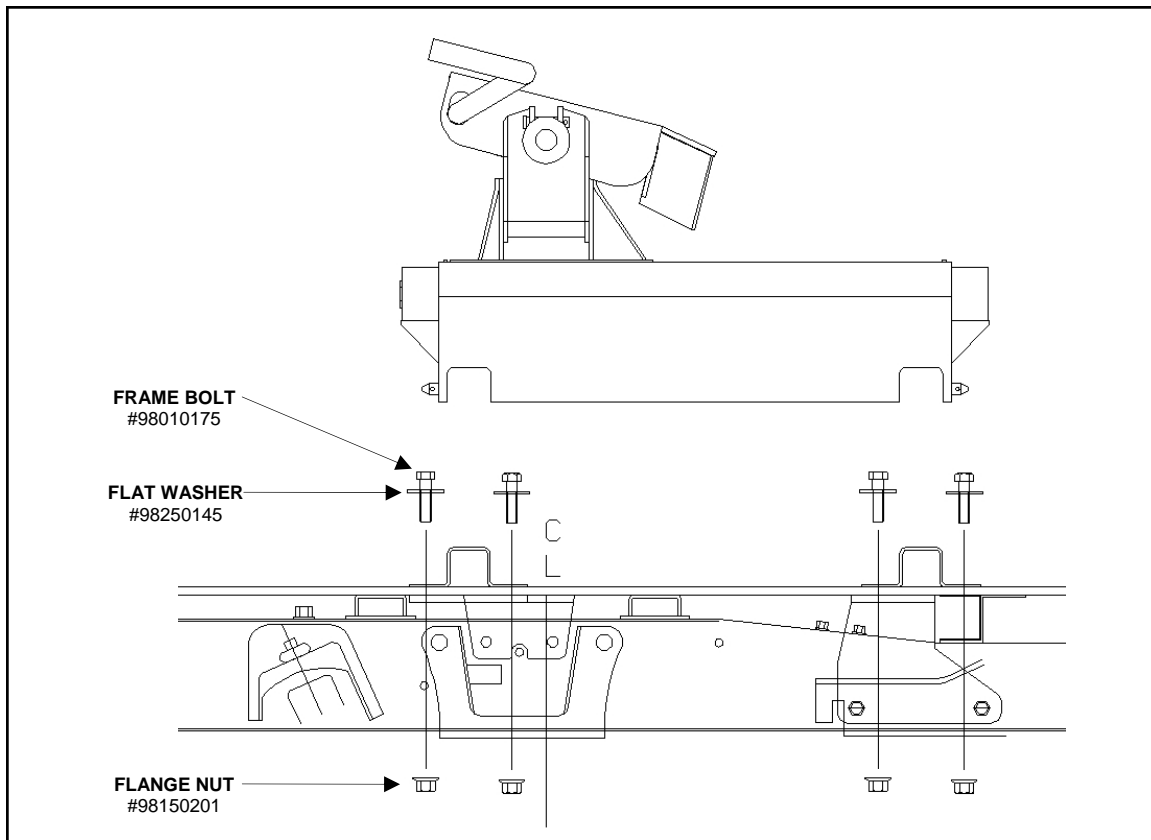

Side View of Installation
Driver's Side

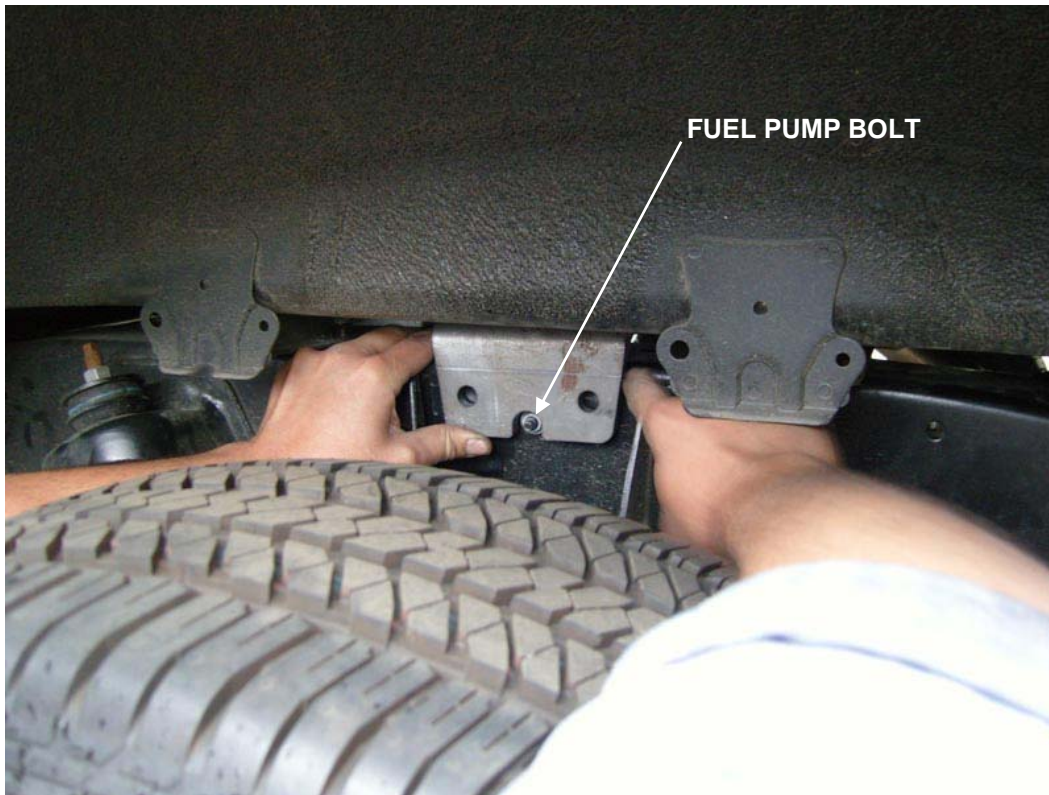

Installation Photo #1
(View of Driver Side Front Mounting Bracket positioned over existing frame bolt)



Installation Photo #2
(Side View of above)

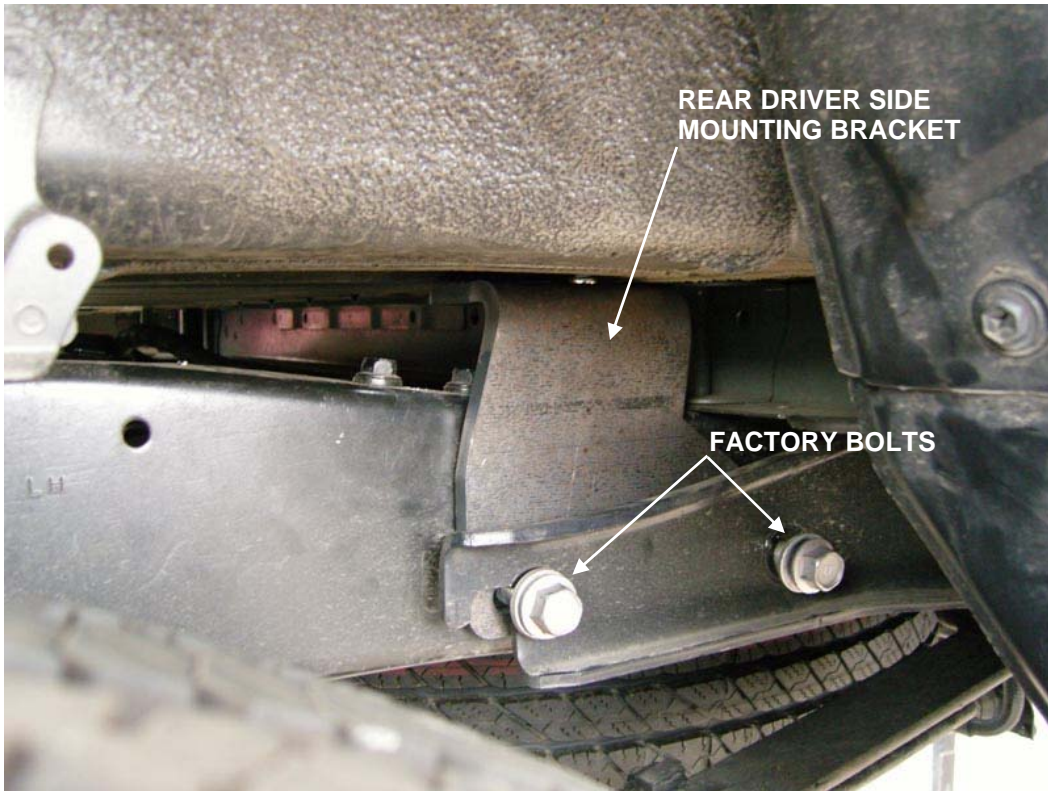

Installation Photo #3
(View of installed Rear Driver Side Bracket “sandwiched” between frame and existing receiver hitch bracket using original factory mounting bolts)

2007 TOYOTA TUNDRA ASSEMBLY — EXPLODED VIEW

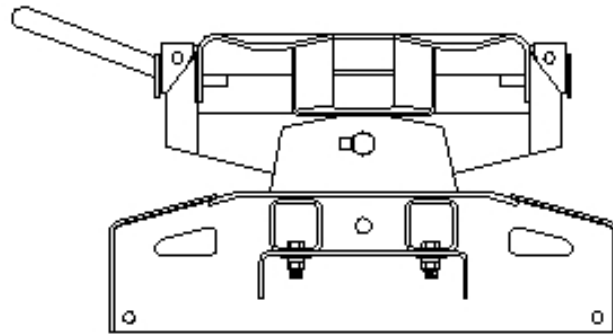

FASTENERS USED FOR BED HOLE LOCATIONS
WHERE MOUNTING BRACKETS ARE USED
See "C" Template/ Layout Method Pg 5

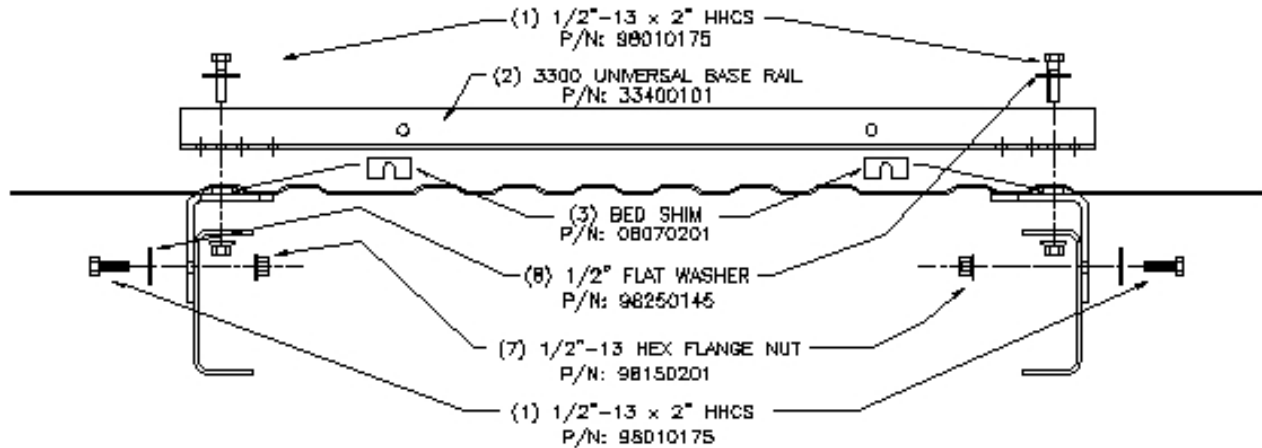

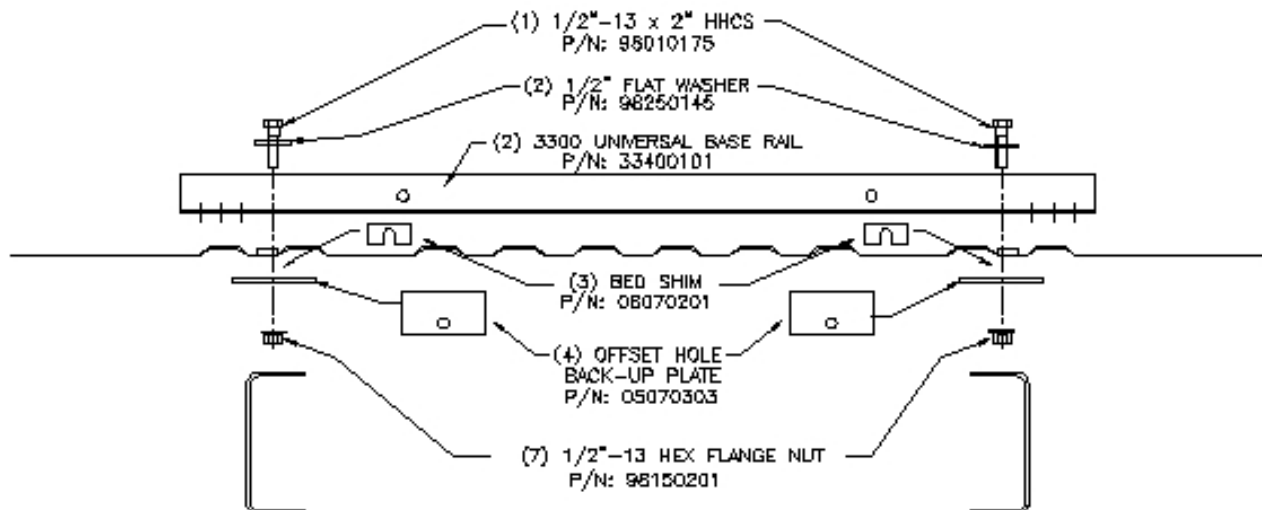

FASTENERS USED FOR BED HOLE LOCATIONS
WHERE NO MOUNTING BRACKET IS USED
See "D" Template/ Layout Method Pg 5



PARTS LIST

#4420 — 2007-2008 TOYOTA TUNDRA MOUNTING KIT			
Description	Part No.	Qty. Used	Material
MOUNTING BRACKET SET	4420	1	(See kit contents listed below)
BASE RAIL	33400101	2	

#4421 — MOUNTING BRACKET SET			
Description	Part No.	Qty. Used	Material
FRAME BRACKET ASSEMBLY FRONT D.S.	442001	1	
FRAME BRACKET ASSEMBLY FRONT P.S.	442002	1	
FRAME BRACKET ASSEMBLY REAR D.S.	442003	1	
FRAME BRACKET ASSEMBLY REAR P.S.	442004	1	
MOUNTING HARDWARE KIT	442005	1	(See kit contents listed below)

#442005 — MOUNTING BRACKET HARDWARE KIT			
Description	Part No.	Qty. Used	Material
1/2" FLAT WASHER	98250145	8	1/2" FLAT WASHER
1/2" - 13 FLANGE NUT	98150201	12	1/2"-13 HEX NUT
1/2" BASE RAIL / FRAME BOLTS	98010175	12	1/2"-13 X 2" HHCS GRD 5
5/16" SLOTTED BED SHIM	08070201	8	
OFFSET HOLE BACK-UP PLATE	05070303	4	

LAYOUT TEMPLATE			
Description	Part No.	Qty. Used	Material
LAYOUT BED TEMPLATE	33400000		ITEM SOLD SEPARATELY