



FORD

SuperRail Mounting Kit

#3361



Installation Instructions

SPECIFICATIONS

- Fits 2004-2014 Ford F-150 w/ 6'5" bed

Table of Contents

Important	3
King Pin Adapter Plate Installation	4-5
Caution	6
Installation Instructions	6
Marking the Bed for Drilling (Layout Method)	6
Template Method	7
Truck Bed Layout Dimension Table	8
Part 1 – Truck Preparation	9
Mounting Bracket Installation	9
Part 2	
Front Mounting Bracket Installation	10
Rear Mounting Bracket Installation	11
Drilling the Bed	12
Installing the Hitch	13-14
Parts List	15

IMPORTANT

DO NOT OPERATE HITCH UNTIL YOU READ THIS SECTION!

1. The SuperGlide hitch was designed to allow the Turntable Cam Arm Assembly to “glide” along two metal tubes, called the Way Tubes. Since it's release in 1998, we have made several advancements in the design, strength, and durability of these components. The Lubrication section of your Owners Manual spans several product releases and design changes. It is *imperative* that you read each section and determine which SuperGlide hitch you purchased, and how to care for it. There have been three major lubrication changes to the SuperGlide hitch:
 - Prior to April 2008, Way Tubes were assembled with either a conventional, quality grade grease or none at all
 - In April 2008, we started coating the Way Tubes with a graphite-based spray lubricant called SlipPlate™
 - November 2009 brings a new innovation from PullRite Towing Systems with the use of plastics. The Turntable Cam Arm Assembly is now equipped with Plastic Wear Plates; see Owners Manual for details (not available for #3600 models)

Depending on when your hitch was manufactured, the Way Tubes of your new SuperGlide hitch will meet one of the above criteria. Each application listed requires some level of maintenance, so it is important that you read the following instructions carefully for the correct lubrication instructions.

Failure to properly lubricate the Way Tubes, as directed in this section, will eventually cause galling between the metals of the Way Tubes and Cam Arm Assembly, which will result in hitch failure. Destruction of various hitch parts is also likely, as well as truck and/or trailer damage, and will not be covered under the Manufacturer's Warranty.

2. **THE TRAILER'S KING PIN BOX MUST BE EQUIPPED WITH A CAPTURE PLATE (UNIVERSAL OR QUICK CONNECT) TO ALLOW THE HITCH TO FUNCTION (MUST BE PURCHASED SEPARATELY). NOTE: IF YOU HAVE PURCHASED A QUICK CONNECT CAPTURE PLATE AND DID NOT RECEIVE INSTRUCTIONS, THEY ARE AVAILABLE ONLINE, OR YOU CAN CONTACT PULLRITE CUSTOMER SERVICE AT (800) 443-2307.**
3. Failure to modify the length of the brake away cable that activates the emergency braking of your trailer, may cause the cable to catch on protruding parts of the hitch. Resulting damage will not be covered by the manufacturers warranty.
4. There should be a minimum of 6” between the truck bed rails and the under side of the trailer for side tilt clearance. It is the customers responsibility to adjust the trailer king pin box for the appropriate amount of clearance.

NOTE: Some truck models are being manufactured with higher bed sides, making it necessary to adjust the height of your trailer's king pin box. If you don't have enough height adjustment available, PullRite produces a 3” Lift Kit that attaches to the rails of your #3100 (ask for part #3108) or #4100, #3300 and #4400 (ask for part #4408; *rated only for 18K when used with model #4400*) SuperGlide models.
5. Some truck beds have contoured bed sides, making the inside bed measurement narrower. Make certain the trailer's king pin box does not contact the inside edge of the bed.
6. Trucks with bed liners may need a tall Mounting Post. See “NOTE” under “Drilling the Bed” for further details.
7. It is the installers and customers responsibility to ensure there is proper clearance between the truck and trailer. There should be a minimum of 2” of clearance as the trailer passes the cab. Call PullRite technical support with trailer width, make and year of truck and distance the king pin is from leading edge of the trailer (See “Caution” section, in the SuperGlide Owners Manual, for measuring procedure) at (800) 443-2307.
8. Read these instructions completely and follow them accurately. Should you have any questions, please call Customer Service at (800) 443-2307 prior to installation for assistance. *If you did not receive your Owners Manual, visit us online at www.pullrite.com or call the number above.*
9. The SuperGlide was designed for short bed pickup trucks. The hitch may function in a longer bed truck, but no mounting brackets exist to make the transfer. Some #4100 and #4400 mounting kits may transfer with modification.

KING PIN TRAILER PLATE INSTALLATION

The following instructions should be followed to install the king pin Trailer Plate.
Note: If more information is needed, Please call PullRite at 1-800-443-2307.

NOTE: IF YOUR TRAILER IS EQUIPPED WITH A MOR/ryde PIN BOX, YOU WILL NEED A SPECIAL ADAPTER. PLEASE CALL MOR/ryde CUSTOMER SERVICE AT 574-293-1581 TO ORDER.

FOR KING PIN BOXES WITH A FLANGE: Figure3.

1. Place the Trailer Plate {J2} over the King Pin, with the guide wedge towards the rear of the trailer (wedge facing down). Align the Trailer Plate {J2} square with the king pin box and clamp in place to prevent movement.
2. Mark the holes for drilling through the Trailer Plate {J2} onto the King Pin Box flange.
3. Remove the Trailer Plate {J2} or use it as a guide and drill 1/4" holes through the flange.
4. Re-install the Adapter Plate (as in step 1).
5. Use the 1/4" bolts provided, to secure the Trailer Plate {J2} onto the king pin box flange. A **minimum of 10 bolts** must be used to fasten the plate on. For use with heavy trailers, more bolts will be needed to secure this plate.

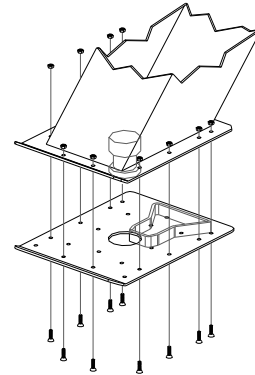

Figure 3

FOR KING PIN BOXES WITHOUT FLANGES: (Figure 4)

1. Place the Trailer Plate {J2} over the King Pin, with the guide wedge towards the rear of the trailer (wedge facing down), and hold in place to prevent movement.
2. The Trailer Plate {J2} can be secured to the King Pin Box sides by welding angle iron supports to the King Pin Box, or use the procedure in step 3. (Angle iron is not provided).
3. For the holes where you cannot reach the backside, drill holes with a #8 drill and tap with a 1/4"-20 tap.
4. If the Trailer Plate {J2} extends beyond the King Pin Box, then install the Knee Braces as shown in Figure 4.
5. Install the Trailer Plate {J2}, using the 1/4" bolts provided, to secure the Trailer Plate {J2} onto the King Pin Box. A **minimum of 10 bolts** must be used to fasten the plate on. For use with heavy trailers, more bolts will be needed to secure this plate. The fasteners used in step 4 **do not** count as part of the minimum number of bolts required.

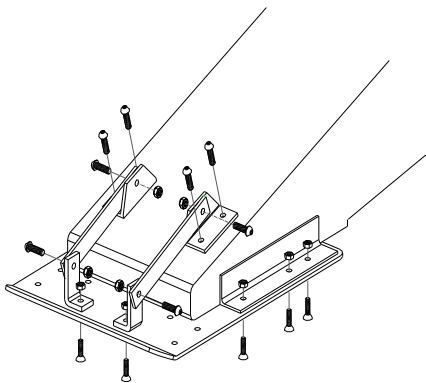

Figure 4

FOR KING PIN BOXES THAT ARE SHORTER FRONT TO BACK: (Figure 5)

1. Place the Trailer Plate {J2} over the king pin, with the guide wedge towards the rear of the trailer (wedge facing down), and measure the distance from the front and rear of the king pin box to the respective edges of the Trailer Plate {J2} (to the bend of the Trailer Plate {J2} in the front). Referring to Figure 5, fashion two plates, 3/16" to 1/4" thick, that will cover the holes of the Trailer Plate {J2} showing in front and rear of the king pin box.
2. While the trailer plate is in position under the king pin box, clamp these plates to both the front and rear of the Trailer Plate {J2}. Remove the Trailer Plate {J2} and drill matching holes in the two support plates with a 1/4" bit using the Trailer Plate {J2} as a guide.
3. Fasten the two support plates to the Trailer Plate {J2} with the 1/4" Bolts {K7} and Lock Nuts {K8} provided.
4. Replace the Trailer Plate {J2} on the king pin box, check for square alignment and **weld** the support plates to the king pin box.
5. Attach the Knee Braces {K2,3 & 4} to the king pin box and the Trailer Plate {J2}. Braces {k2} may have to be welded on if the interior of the king pin box is not accessible.

Note: Kit # 331703 consisting of pre drilled support plates are available from PullRite but are not part of the stock Trailer Plate Kit. Kit # 331703 was designed to fit the 8"x12" Lippert pin box. This method of attaching the Trailer Plate {J2} should allow **10 bolts** to be used.

CAUTION: When using kit #331703 on slightly larger pin boxes, it may be necessary to trim the plates for proper fit—when installed, the provided trailer plate adapter (3317) should be flush against the bottom of the trailer's king pin plate.

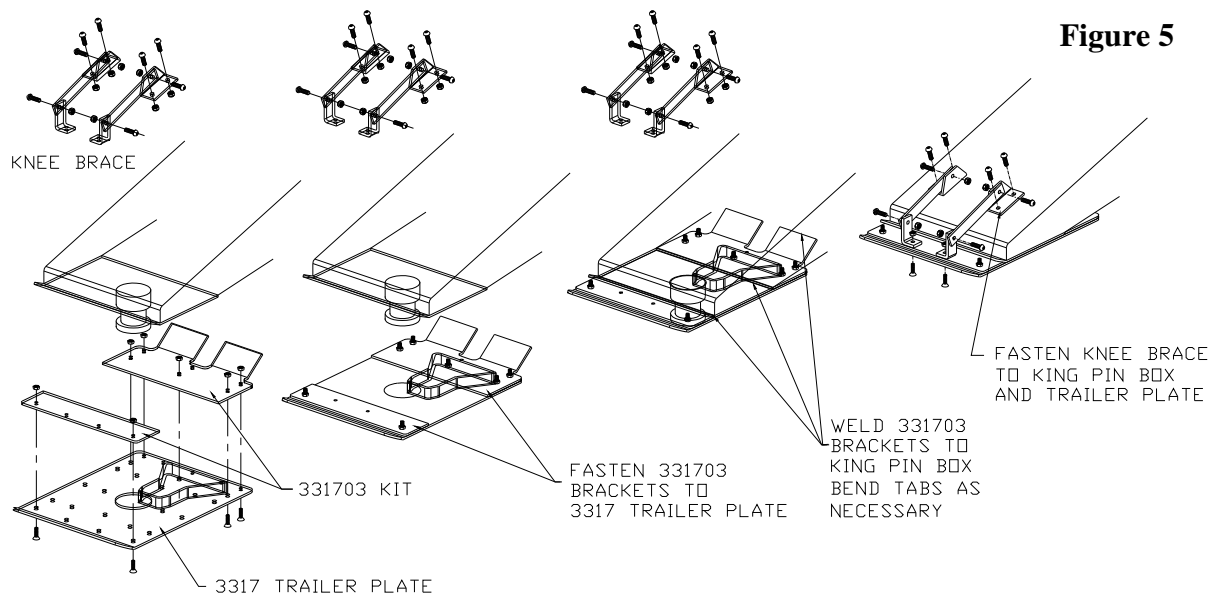

Figure 5

CAUTION

1. As a general rule, for the SuperGlide hitch to maintain proper clearance to the truck, the leading edge of the trailer (measured at the corner) should be even with the center of the king pin. Most truck trailer combinations will allow 102" wide trailers if the king pin is located as described. Narrower trailers will allow the king pin to be "tucked" under the trailer over hang to some extent (Figure 1). Call PullRite technical support with trailer width, make and year of truck and distance the king pin is from leading edge of the trailer (Dimension "A"). 1-800-443-2307

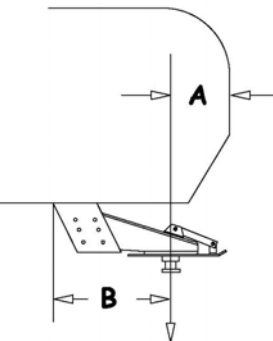

Figure 1

2. Using a trailer that has a long rear slope to the King Pin Box Hangar, "B" in (Figure 1), may cause damage to the trailer or truck bed during turns. Dimension "B" must be less than one half the width of the inside top edges of the bed. Please call PullRite technical support, 1-800-443-2307, if more information concerning this problem is needed.
3. The SuperGlide hitch is equipped with a side to side pivot feature. There should be a minimum of 6" between the truck bed rails and the under side of the trailer for side tilt clearance. It is the customers responsibility to adjust the trailer king pin box for the appropriate amount of clearance depending on the terrain being traveled (example: some State Parks are sloped and unpaved; some driveways are steeply angled). If bed covers are added, care must be taken to allow for additional clearance.

Installation Instructions

Truck Preparation

1. Check part quantities using the **Parts List**.
2. Block vehicle wheels. Some vehicles may require you to raise the rear of the truck in order to make it easier to drill for installing the Mounting Brackets on the truck frame.
3. You may wish to remove the wheels, to give yourself greater working room.
4. At this point, the bed should be laid out and marked for drilling using either the LAYOUT METHOD or the TEMPLATE METHOD.

Marking Bed for Drilling (layout method)

1. For layout using the Template method, see *Layout (Template Method)* on next page.
2. See **Truck Bed Layout Dimensions** table **pg. 7** for the dimension values for items **A-D** located in the 'LAYOUT METHOD' illustration. Measure and mark from the back of the bed forward the values for **A** and **B**. Do this at any point on both sides of the bed.

3. Draw a line across the bed from mark to mark.
4. Find the centerline of the bed. Draw a line down the middle of the bed from front to rear. See **Figure 3 on pg. 7**. Center the measurement of **C** across the centerline at the front most line you made in step 2, and mark the measurement on each side (parallel to the centerline). Center the measurement of **D** for the rear most line made in step 2, and again mark the measurement on each side (parallel to the centerline). This will locate the 4 drill holes.
5. Go to the Index and look for your truck **SPECIFIC LISTING** and do the steps listed in **PART I**. The truck **Specific Listings** begin after **page 7** of these instructions. (See the **Table of Content** for your specific application).

Drilling the Bed

1. After you have removed the Mounting Brackets, use a **1 3/4"** hole saw, centered over the **1/16"** pilot hole, cut the bed for the mounting posts.
2. De-bur inside the holes, then use a paint stick to touch up the edges.
3. Re-install the Mounting Brackets and secure those that have no existing mounting holes in a temporary fashion, using 'C' clamps. Those that have holes, secure by lightly attaching with bolts (tighten sufficiently to where the Mounting Brackets lay flat against the truck frame).
4. Install the Mounting Posts through the bed into the Mounting Bracket Post Holders. Rotate the Posts a quarter turn. (**See the illustrations in the truck specific listings**)

NOTE: *The Mounting Post should be tall enough to clear most bed mats. Vehicles using bed liners may require taller Mounting Posts to seat into the Post Holders properly. A Tall Mounting Post is available under part # 330705. Four posts are required for installation.*

5. Remove the SuperGlide hitch from the shipping carton. Remove the Base Rail assembly from the base, leaving the Base Rail Extensions loose to allow lateral movement as you place the Rail assembly over the Mounting Posts. See drawing on next page.
6. Install the Base Rails in the bed of the truck, and center the Base Rails between the Base Rail Mounting Posts. Finger tighten the Base Rail mounting Bolts.

Torque Table

- 3/8" Bolt — 31 ft. lbs.
- 1/2" Bolt — 75 ft. lbs.
- 5/8" Bolt — 151 ft. lbs.
- 3/4" Bolt — 266 ft. lbs.

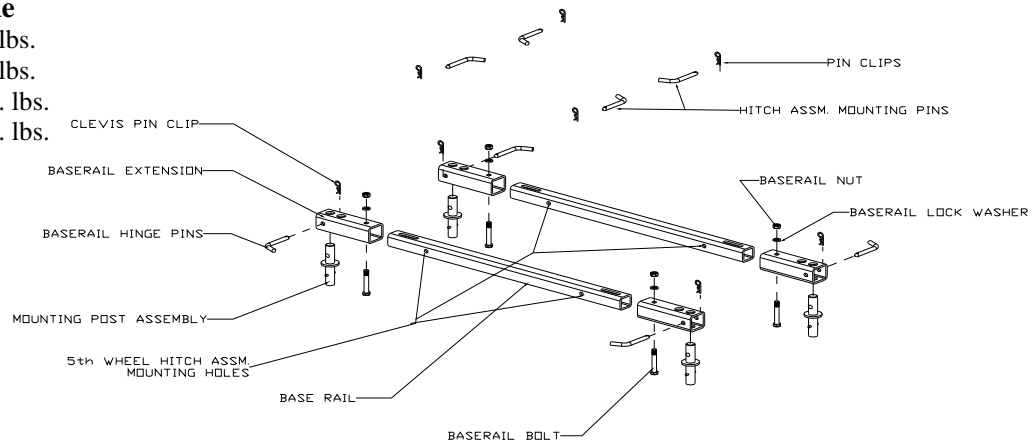

Base Rail parts identification

7. Set the SuperGlide Hitch on the Base Rails, and align the Hitch Assembly with the Base Rail mounting holes, using a drift pin punch to aid your alignment. Install the Mounting Pins from the inside. Then install the Pin Clips, to secure the Hitch assembly to the Base Rails. See drawing on next page.
8. Center the Hitch assembly within the truck bed, from side to side. You might need to use a rubber mallet to get the unit to move while centering. Once the unit is centered, tighten the Base Rail Extension Bolts to 85 ft. lbs.
9. The SuperGlide Hitch, and the Base Rails, must be removed to verify that the Mounting Post can be inserted and removed freely, without binding. A slight adjustment might be required to obtain unrestricted access.
10. Reinstall the Mounting Posts, the Base Rails, and the SuperGlide Hitch assembly.
11. Complete the final steps needed to install the Mounting Brackets to the truck frame. Go to the truck **Specific Listings, Part II** at this time .

Layout (Template Method)

1. Lay the Template in the truck bed, centering it from side to side, and parallel to the end of the truck bed, using the dimension **X** listed in **Truck bed layout dimension** table on pg. 7.
2. Mark the 4 holes, while making sure the template does not move.
3. Go to the truck **SPECIFIC LISTING** and begin with the steps listed in **PART I**.

LAYOUT METHOD

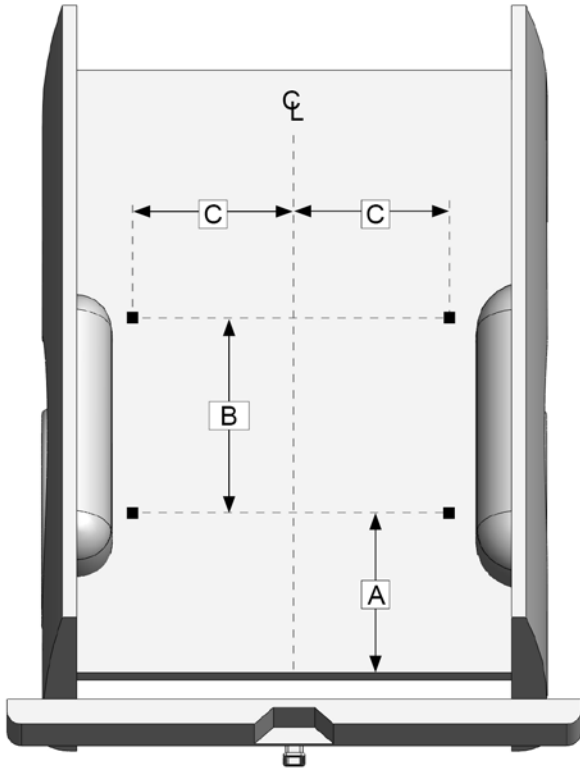

TEMPLATE METHOD

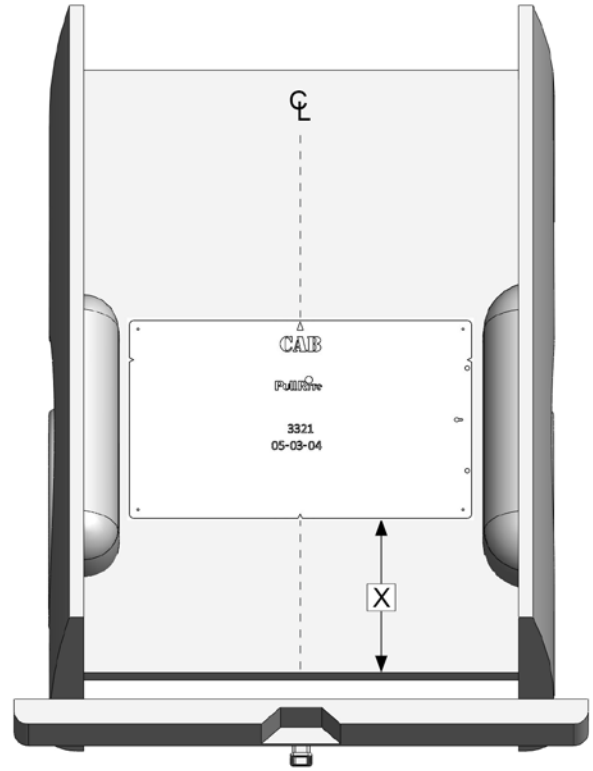

Figure 3

NOTES: The **TEMPLATE** should be orientated as shown in **Figure 3** above. Notice that the spacing of the forward and rearward facing holes may be different, and can be used to determine the correct orientation of the template. Item "C" in the table below shows the forward facing dimension, and Item "D" , the rearward facing dimension.

INSTALLATION TIP: The template has a tendency to move when placed on the slick paint of new truck beds, and it may be helpful to place a small piece of **NON-SKID** matting, such as "SCOOT-GARD"™, to help keep the template from moving. Also, cover the top Mounting Post hole of each bracket with masking tape then when the small pilot holes are drilled in the bed the bit will also pierce the tape allowing you to accurately see the relative location of the bed hole to the Mounting post hole.

Truck bed layout dimensions—For 6' bed (short bed) trucks only

	FIT YEARS	"A"	"B"	"C"	Template Mode "X"	Template Part #	FRAME HOLES
Ford F150 3321 & 3361	2004-2013 F150 6 1/2' BED	24 27/32"	21 3/16"	38 1/4"	23 27/32"	33210000	NO DRILL

FORD F150 3321/3361

SPECIAL NOTE: The F150 truck has bed sides that are 2” higher than other trucks. This may cause bed to trailer clearance problems. PullRite suggests that you investigate these potential problems with the user before installing the hitch.

FORD F150 3321 HARDWARE

QTY	DESCRIPTION
12	1/2”-13 x 4-1/2” HHCS
16	1/2”-13 Flange Nut
4	1/2”-13 x 5-1/2” HHCS

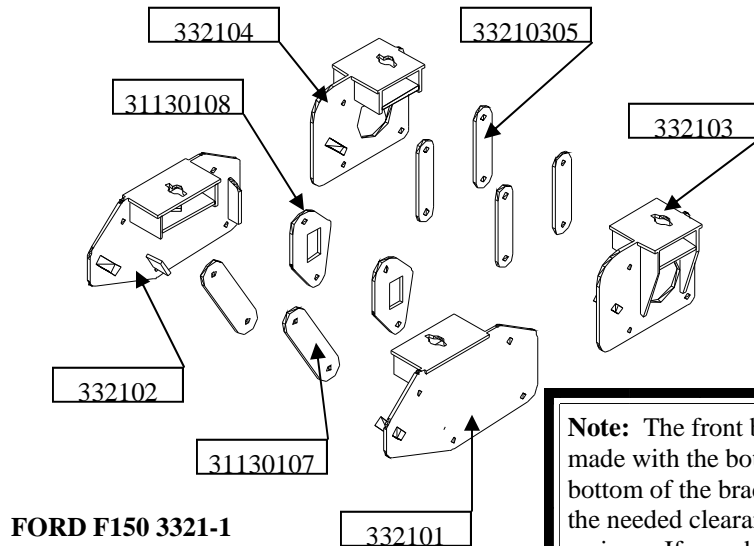

FORD F150 3321-1

Note: The front brackets, part #'s 332101 & 332102, are now made with the bottom of the bracket offset from the top. The bottom of the bracket now sits flush against the frame to allow the needed clearance of the “U” bolts that attach the axle to the springs. If your brackets are not offset, please call the factory at 800-443-2307 to obtain the correct brackets.

FORD F150 3321-2

VIEW OF DRIVER SIDE

PART I *Truck Preparation*

1. Remove the spare tire.

Mounting Bracket Installation.

1. Figure **Ford F150 3321-2** illustrates the drilling of the truck bed, using a 1/16” drill. Drill the four pilot holes in the truck bed where you marked the bed during Truck Bed Layout.
2. Temporarily fasten the Mounting Brackets to the frame by following the steps in **Part II** on the next two pages or by clamping the mounting brackets to the frame following the same location instructions in **Part II**.
3. By leaving the 1/16” drill bit protruding through the bed, the bit should come down through the Post Holder of the Mounting Bracket, centered front to rear and side to side. There is some latitude in the fore and aft location of the Rear Mounting Bracket (not much) but **none** for the Front Mounting Bracket. If the bit is not centered in the Front Mounting Bracket Post Holder the location of **all** the bed holes **must** be adjusted accordingly. **Installation tip:** Cover the top of the Mounting Post hole of each mounting bracket with masking tape then when the small pilot holes are drilled in the bed the bit will also pierce the tape allowing you to accurately see the relative location of the bed holes to the Mounting Post holes.
4. Once the bed hole locations are correct, remove the Mounting Brackets and return to Drilling the Bed on page 6.

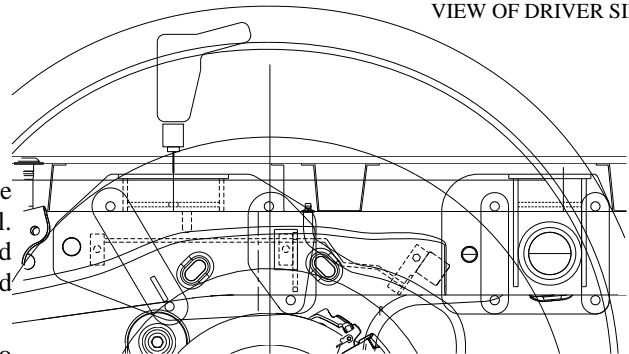

PART II *Front Mounting Bracket Installation*

Attach the Front Mounting Brackets to the frame using four 1/2"-13 x 5 1/2" bolts, 1/2" Flange Nuts, the Rear and Front Backer Plates. Slide the Mounting Post Holder portion of the Mounting Bracket over the top of the frame while guiding the 15/16" round pin located at the front of the Mounting Bracket into the existing hole in the frame designated in the drawing below. The brake line bracket on the driver side must be pried out of the frame in order to install the Rear Backer Plate.

FRONT MOUNTING BRACKET, DRIVER SIDE

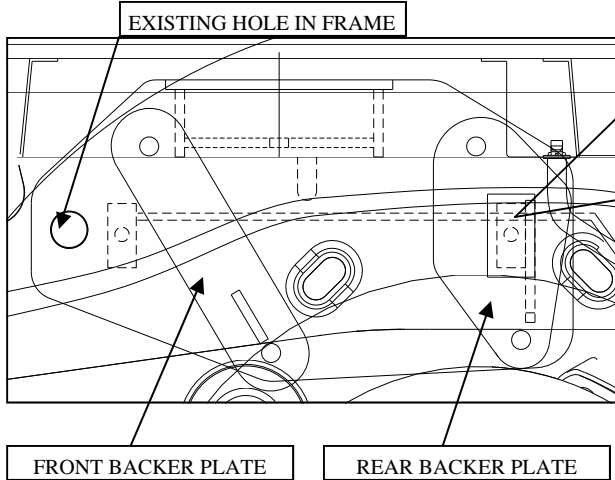

View of the existing hole for the Front Bracket on the drivers side.



View of the Front Mounting Bracket installed on the passenger side.



PART II Rear Mounting Bracket Installation

Attach the Rear Mounting Brackets to the frame using four 1/2"-13 x 4 1/2" bolts, 1/2" Flange Nuts and Backer Plates. Slide the Mounting Post Holder portion of the Mounting Bracket over the top of the frame while guiding the 3/4" round pin located at the front of the Mounting Bracket into the existing hole in the frame designated in the drawing below. The electrical line located on the driver side must be pried out in order to install the rear Backer Plate.

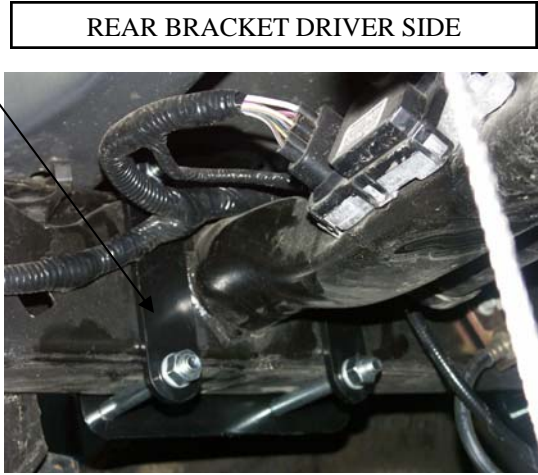
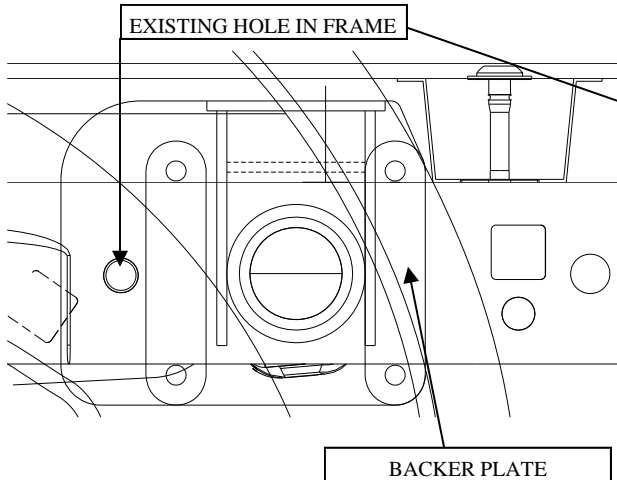

DRILLING THE BED

Locate bed holes using the template method or the Lay out method. See pages 5 through 7. Use template number 332100.



Drill 1/16" pilot holes.



After checking the holes in the masking tape covering the Mounting Post holes in the Mounting Brackets and making any necessary adjustments in the bed hole locations, drill the four 1-3/4" holes in the bed at the pilot hole locations.



Debur the edges of the large bed holes and remove any drill shavings from the bed.



INSTALLING THE HITCH IN THE BED

Use paint stick to dress raw edges.



Remount all Mounting Brackets leaving the fasteners finger tight. Then insert the four Mounting Posts, rotate them so that the round hole in the top faces fore and aft.



Set the hitch over the Mounting Posts and tighten all Mounting Bracket fasteners. Then center the hitch between the Mounting Posts and tighten the Base Rail fasteners.



INSTALLING THE HITCH IN THE BED

Remove the Hitch from the bed to make sure every thing lines up correctly.



Remount the Hitch.



Consult your Owner's Manual for your hitch model and the correct lubrication to use on the Way Tubes. Check the condition of your Way Tubes, and if needed, apply lubricant according to your Owner's Manual instructions.



3361 FORD F150 SUPER RAIL MOUNTING KIT

Description	Part No.	Qty. Used	Material
3321 MOUNTING BRACKET KIT	3321	1	KIT
3321 HARDWARE KIT	332105	1	KIT
3300 BASE RAIL KIT	3307	1	KIT

3307 BASE RAIL KIT

Description	Part No.	Qty. Used	Material
BASE RAIL	33070001	2	2" SQ. x 1/4" WALL TUBING
BASE RAIL EXTENSION	330702	4	2.5" TUBE ASSEMBLY
MOUNTING POST	330705	4	1" ROUND ASSEMBLY
BASE RAIL HINGE PIN	08060001	4	1/2" ROUND
CLEVIS PIN CLIP	98410127	4	#3 COTTER PIN
BASE RAIL BOLT	98010183	4	1/2"- 13 x 3" HHCS GRD 5
BASE RAIL LOCK WASHER	98200142	4	1/2" LOCK WASHER
BASE RAIL NUT	98150153	4	1/2"- 13 HEX NUT

Note: The front brackets, part #'s 332101 & 332102, are now made with the bottom of the bracket offset from the top. The bottom of the bracket now sits flush against the frame to allow the needed clearance of the "U" bolts that attach the axle to the springs. If your brackets are not offset, please call the factory at 800-443-2307 to obtain the correct brackets.

3321 MOUNTING BRACKET KIT

Description	Part No.	Qty. Used
FRAME BRACKET ASSEMBLY FRONT D.S.	332101	1
FRAME BRACKET ASSEMBLY FRONT P.S.	332102	1
FRAME BRACKET ASSEMBLY REAR D.S.	332103	1
FRAME BRACKET ASSEMBLY REAR P.S.	332104	1
FRONT BRACKET, FRONT BACKER PLATE	31130107	2
FRONT BRACKET, REAR BACKER PLATE	31130108	2
REAR BRACKET, BACKER PLATE	33210305	2
REAR BRACKET, BACKER PLATE	33210305	4
MOUNTING BRACKET HARDWARE KIT	332105	1

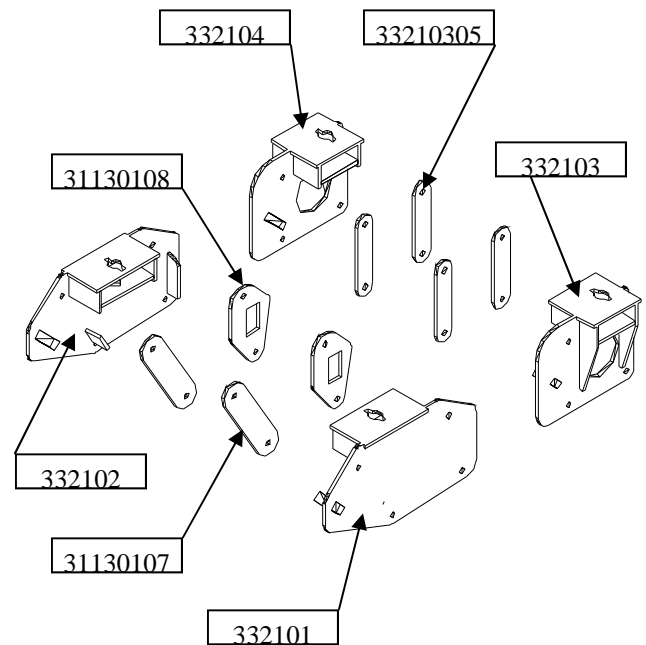

332105 MOUNTING BRACKET HARDWARE KIT

Description	Part No.	Qty. Used	Material
1/2", FRAME BOLTS, FRONT BRACKET	98010203	4	1/2"-13 x 5 1/2" HHCS GRD 5
1/2" FLANGE NUTS	98150201	16	1/2"-13 SERRATED FLANGE NUT
1/2" REAR BRACKET FRAME BOLTS	98010195	12	1/2"-13 x 4 1/2" HHCS GRD 5
LAYOUT TEMPLATE	332100		NOT INCLUDED IN KIT



MANUFACTURED BY:

PULLIAM ENTERPRISES, INC.

13790 East Jefferson Blvd.

Mishawaka, IN 46545

(574) 259-1520 • (800) 443-2307

info@pullrite.com • www.pullrite.com