

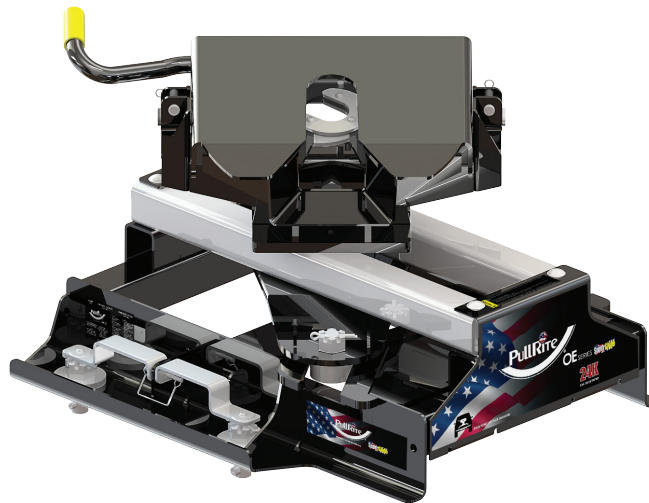

OWNER'S MANUAL



#4500 (24K) OE Series SuperGlide

Gross Trailer Weight (Maximum).....24,000 lbs
Vertical Load Weight (Max.Pin Weight).....5,000 lbs

Fits 2020 and newer GM trucks w/ OE Prep Package

The following instructions provide valuable information regarding the function and proper use of the OE Series SuperGlide Fifth Wheel Towing System.

YOU MUST COMPLETELY READ THE INSTRUCTIONS WITHIN THIS MANUAL, PRIOR TO OPERATING THE HITCH TO PREVENT UNNECESSARY DAMAGE TO THE HITCH, VEHICLE, OR TRAILER.

ALL PULLRITE HITCHES TESTED TO SAE J2638 STANDARDS • MADE IN THE USA

For more information, please call PullRite at (800) 443-2307.

TABLE OF CONTENTS

SYSTEM WEIGHT RATING vs. COMPONENT WEIGHT RATING.....	3
HOW DOES SUPERGLIDE WORK?.....	4
CAUTION AND TESTING CLEARANCE.....	5
MAINTENANCE.....	6
LUBRICATION.....	6,7
ATTACH HANDLE TO HEAD PLATE.....	8
FIFTH WHEEL PLATE OPERATION.....	9,10
HITCH INSTALLATION.....	11
BUILD THE POST ASSEMBLY.....	12
MOUNTING POST INSTALLATION.....	13
MOUNTING POST ADJUSTMENT.....	14
HITCHING.....	15
SAFETY CHECKS & UNHITCHING.....	16
ADJUSTING THE CAM ARM ASSEMBLY.....	17
CHALLENGE VS SOLUTION.....	18
FREQUENTLY ASKED QUESTIONS.....	19
EXPLODED VIEW.....	20
PARTS LIST #4500.....	21
LIMITED WARRANTY.....	i
PRODUCT REGISTRATION.....	ii

SYSTEM WEIGHT RATING vs. COMPONENT WEIGHT RATING

A towing system includes each vehicle and component involved in towing. Each item in your towing system has a capacity or weight rating. Your trailer has a Gross Vehicle Weight Rating or GVWR. Your truck has a towing capacity, a payload capacity, and possibly more. In addition, your fifth wheel hitch has a weight rating. This weight rating must be at, or above, the GVWR of your trailer for you to tow safely. In addition, if your truck can tow larger loads (has a larger capacity) than the rating of your hitch, your system is only safe to tow loads at the lower rating, that of the hitch.

Your gooseneck ball will also have a weight rating, just like your fifth wheel hitch. Many times, these ratings are designed to match, but this is not always the case. Your gooseneck ball may be higher rated than your fifth wheel hitch, but it also could be lower depending on the components involved. The lowest rating of any one component in the system becomes the rating of the entire system. If your ball is rated to 18,000 lbs., and your hitch is rated at 24,000 lbs., the weight rating of the entire system will not be above 18,000 lbs. Other components in the system could lower the actual system rating further.

It is the end users responsibility to ensure a safe towing experience. To this end, it is your responsibility to ensure that the truck, trailer, hitching components, and all other items involved are rated or have a capacity sufficient for the loads involved.

HOW DOES SUPERGLIDE WORK?

The SuperGlide is an automatically sliding fifth wheel hitch based on a mechanical, cam action. Other sliding hitches on the market today require you to get in and out of the vehicle multiple times before and after a turn, throwing levers to allow it to move back and forth. The cam action of the SuperGlide hitch is truly automatic. When installed in your short bed truck and used in conjunction with our Capture Plate, the SuperGlide “glides” along the Way Tubes with ease, making turns automatically, without you having to ever get out of your vehicle. Here’s how it works:

Equipping your trailer’s king pin box with one of our Capture Plates (required for the hitch to function properly and sold separately), restricts the king pin on your trailer from turning in the fifth wheel plate on the SuperGlide. Once the truck begins to make a turn, the “captured” fifth wheel plate forces the large roller of the turntable cam arm assembly to rotate and roll along the path of the cam slot to begin the turn. This action pulls the plate and turntable assembly, with trailer in tow, away from the cab of your truck. The more you turn, the more it moves back.

It is important to note that the width of the trailer and the location of the king pin in relation to the “nose”, or leading edge of the trailer, is critical in determining if your truck and trailer are compatible to be used with a SuperGlide. Short bed trucks have only so much room from cab-to-axle; if your king pin is located too far under the nose of the trailer, the cam action of the SuperGlide may not move the trailer back fast enough to allow the necessary clearance.

Another important point in the use and maintenance of your SuperGlide is the need to lubricate the moving parts. SuperGlide hitches manufactured after November 2009 are equipped with Low Friction Polymer Wear Plates and require a light oil application to enhance the movement of the Turntable Cam Arm Assembly on the Way Tubes.

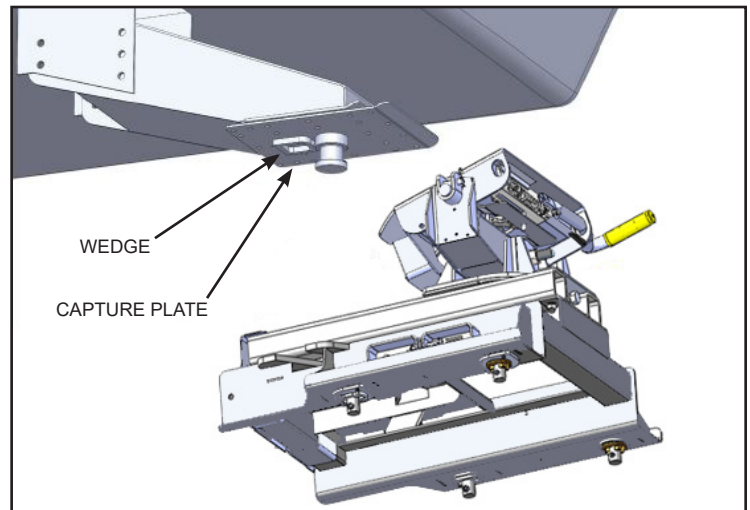

The #4500 SuperGlide is equipped with Low Friction Polymer Wear Plates on the Turntable/Cam Arm Assembly to eliminate the need for constant lubrication between the metals of the Turntable and the Way Tubes. It is important to protect the Wear Plates from possible damage by keeping the Way Tubes free from rust and corrosion by applying a coating of light oil on the Tubes and the Turntable Shaft.

**BEFORE OPERATING YOUR SUPERGLIDE HITCH,
YOU MUST READ THE “LUBRICATION” SECTION.
IF YOU HAVE ANY QUESTIONS REGARDING
LUBRICATION OR HOW THE SUPERGLIDE
FUNCTIONS, PLEASE CONTACT OUR CUSTOMER
SERVICE DEPARTMENT AT (800) 443-2307 BEFORE
USING YOUR SUPERGLIDE.**

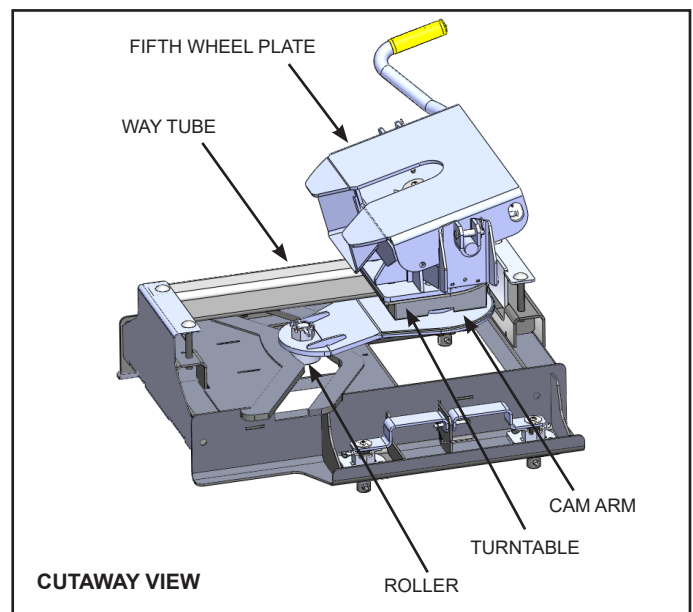

CAUTION

- The width of the trailer and the location of the king pin in relation to the “nose” (Dimension A), or leading edge of the trailer, is critical in determining if your truck and trailer are compatible to be used with SuperGlide. If your king pin is located too far under the nose of the trailer, the cam action of the SuperGlide may not move the trailer back fast enough to allow the necessary clearance. Call PullRite Customer Service at (800) 443-2307 with trailer width, make and year of truck, and the distance of the king pin from the leading edge of the trailer (Dimension A).
- Using a trailer that has a long rear slope to the king pin box hangar, “B”, may cause damage to the king pin box or the inside edge of the truck bed. Dimension “B” must be less than one half the width of the inside top edges of the bed during turns for proper clearance.
- The SuperGlide hitch is equipped with a side-to-side pivot feature. There should be a minimum of 6” between the truck bed rails and the under side of the trailer for side tilt clearance. It is the customer's responsibility to adjust the trailer king pin box for the appropriate amount of clearance depending on the terrain being traveled (example: some State Parks are sloped and unpaved; some driveways are steeply angled). If after-market bed covers are added, care must be taken to allow for additional clearance.
- The SuperGlide hitch is designed to allow you to make a 90° turn. Please use extreme caution when turning this far. In addition to putting stress on the wheels and axles of your trailer.

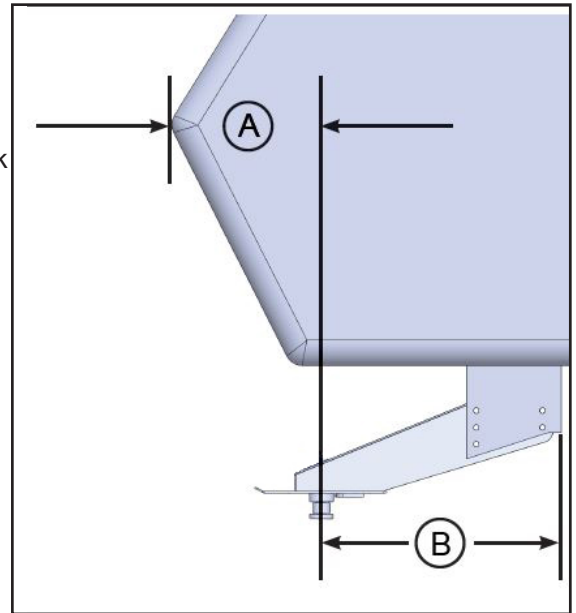

IMPORTANT: Please be aware that if you make a turn greater than 90° the trailer will contact your truck and you WILL damage various parts of the hitch which will NOT be covered under the manufacturer's warranty.

- Position your brake cable so the slack in the cable will not be allowed to catch on the hitch during turns or lodge in the cam mechanism. Failure to modify its length may cause the cable to catch on protruding parts of the hitch which could activate the trailer brake, causing damage to the truck, trailer or hitch. Resulting damages will not be covered by warranty.
- Position or coil any slack in your 7-way electrical cable out of the way of your moving hitch. It is preferred that the plug and cabling remain isolated rearward of the hitch (nearest the tailgate) to prevent damage. Make slow test turns while observing the 7-way cable until you are satisfied that it will not become caught in the hitch mechanism.
- Anything carried in the bed of your truck during towing will need to be well secured. Remove any foreign debris that might move around in the bed and contact the hitch. **This will help to ensure that nothing will get caught in or jam the movement of the cam which can cause damage to the hitch.**

TESTING CLEARANCE

When you are assured your trailer is safely hooked up, pull forward and slowly start to turn. Make sure that someone is outside watching the distance between the cab and the trailer. The distance between the cab and trailer should be greater than two inches at all points of the turn. Specifically watch the distance when the corner of the trailer is closest to the cab and also when nearing a 90 degree turn. The minimum two inches of clearance is needed for normal driving conditions. The practice of testing clearance will let you know how much clearance you actually have should you encounter adverse road conditions.

EXAMPLE: It is possible for the trailer to hit the cab when turning through a dip where the corner of the trailer is closest to the cab or when nearing a 90° turn.

LUBRICATION

DO NOT OPERATE HITCH UNTIL YOU READ THIS SECTION!

The SuperGlide hitch was designed to allow the Turntable Cam Arm Assembly to “glide” along two metal tubes, called the Way Tubes. Since it’s release in 1998, we have made several advancements in the design, strength, and durability of these components. The Turntable Cam Arm Assembly is equipped with innovative Low Friction Polymer Wear Plates. It is imperative that you read each of the following sections so you can learn how to care for your hitch properly.

MAINTENANCE

Inspect all mounting bracket and hitch hardware, that it is securely fastened. The Fifth Wheel Plate should be removed and inspected, checking all moving parts for wear. Inspect all mounting bolts periodically for tightness and general condition.

#4500 model utilizes a castle nut and pin in the roller assembly. To re-torque, remove cotter pin and tighten roller bolt to a minimum of 125 ft. lbs., then tighten more until next nut slot aligns with the stud cotter pin hole. Install cotter pin and bend one leg upward.

When storing the SuperGlide hitch, you should be sure that the Fifth Wheel Plate parts and Way Tubes are lubricated with WD-40 to retard the formation of rust. Cover the entire assembly to prevent accumulation of dirt, grime, or rust.

HITCH LUBRICATION

The Low Friction Polymer Wear Plates of the SuperGlide’s Turntable Cam Arm Assembly were designed to glide along the surfaces without the need for heavy lubrication. It is crucial to protect against rust and to enhance the ease of turning on the Way Tubes, otherwise the hitch will not function properly possibly causing damage to the hitch. Use a light oil (WD-40 or a 3-in-1 oil) applying it to the Way Tubes’ top and inward facing sides and between the front and rear openings in the Wear Plates positioned around the Turntable/Cam Arm Shaft.

A light lubricant that is applied more frequently (each day of use) is preferred over the use of heavier lubricants. Since any applied lubricant is going to be “wiped” off by the sliding action of the hitch, a light lubricant applied more frequently will perform better (reduce the friction between the polymer and steel surfaces), and will be less messy, as well as attract less dust and dirt. Heavy grease will be “wiped” off just as fast as a light lubricant pushing the heavy grease to areas that will not benefit the wear surfaces - only making it appear that the hitch is still well lubricated when it’s actually not.

You will find with use, that the Low Friction Polymer Wear Plates will wear the shiny zinc coating off the Way Tubes in areas, creating “bare” areas of the metal, as well as light scoring marks in areas of repeated use. This is normal, but will be protected as you apply WD-40 to the Way Tubes with each day’s use.

If your hitch is unused for more than a day or it is in storage, rust can form quickly in these areas. If rust does form, simply use steel wool or lightly sand those areas. Never let your tubes become pitted with rust, as it may cause the polymer to tear or catch on rough areas. The Wear Plates have a long life expectancy, but depending on how often, and what terrains you are traveling, the polymer will eventually, wear down with time. If the 1/4” polymer plate wears down to 3/16”, it should be replaced.

WARNING: Do not use any lubrication other than a light oil on the Way Tubes of your SuperGlide hitch. Using other lubricants, such as those with a silicone base, will create a residue and may hinder the functionality of the Turntable Cam Arm Assembly. Buildup of old oil and dirt can also create a residue over time and needs to be kept clean.

LUBRICATION

DO NOT OPERATE HITCH UNTIL YOU READ THIS SECTION!

WAY TUBES: Cover the tops and inside face of each Way Tube with WD-40.

TURNTABLE SHAFT: Using a directional straw attached to the spray nozzle, direct oil between the openings in the Low Friction Polymer Wear Plates at both the front and rear.

PIVOT BOLT AND ROCKER ARM: Inspect and lubricate the Pivot Bolt monthly with axle grease when heavily used, or annually with light use. To remove the pivot bolt for lubrication:

1. Remove the Fifth Wheel Head Plate from the Rocker Arm.
2. Remove the Hex Nut and Lock Washer from the Rocker Arm Pivot Bolt.
3. Place downward force, compressing the Rocker Arm Spring, enabling the Pivot Bolt to be removed.
4. Lube the Pivot Bolt generously with a quality axle grease and reinstall. Tighten the Pivot Bolt to the point where there is resistance when you move the Rocker Arm side-to-side.

HITCH PINS: A light coating of lubricant such as WD-40 or 3-in-1 oil on the hitch pin and clips will help you install and reinstall them easily.

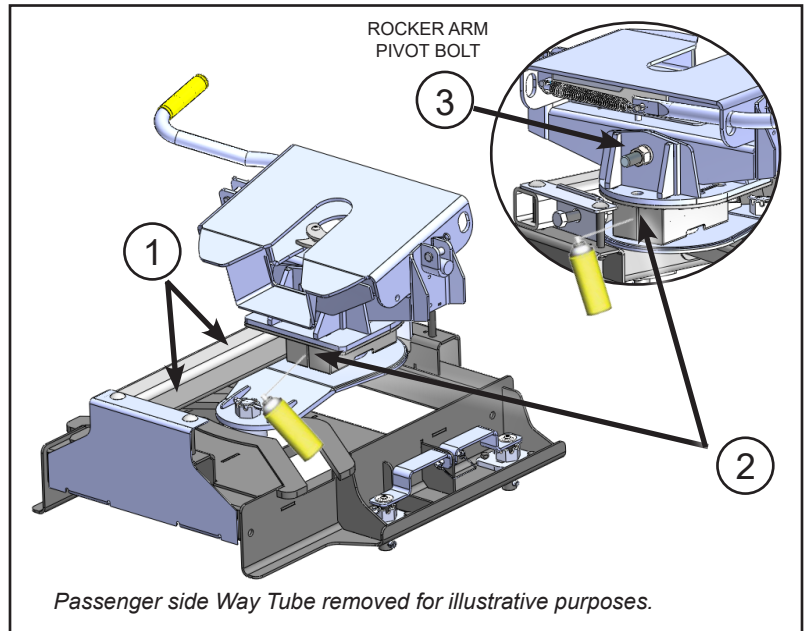

FIFTH WHEEL PLATE & KING PIN

The plate and it's moving parts should be lubricated with a light lubricant such as WD-40 or 3-in-1 oil, before each trip and as needed.

Pull the Release Handle repeatedly so that the lubricant will spread among the moving parts that may not have otherwise been covered sufficiently. Be sure the plate is free of dirt and old oil buildup.

Be sure the trailer's king pin is clean and free from rust and apply lubricant to the king pin.

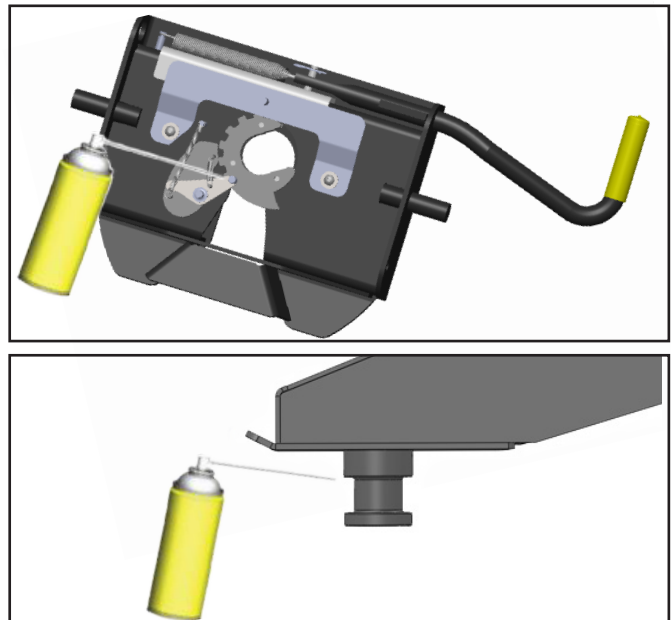

ATTACH HANDLE TO HEAD PLATE

1. Remove the hitch pin clip from the spring post and Insert handle through obround hole.

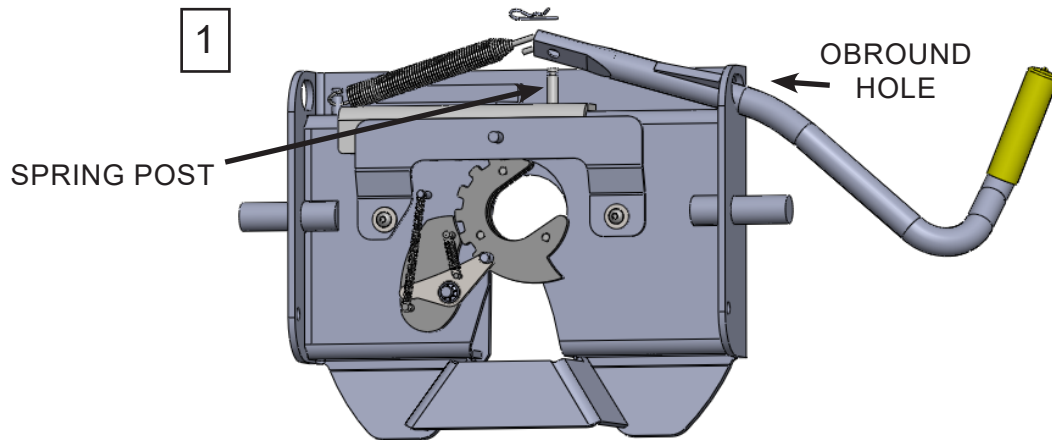

2. Detach the spring from the spring post and stretch hook inside handle so it reaches beyond the hole in the handle.

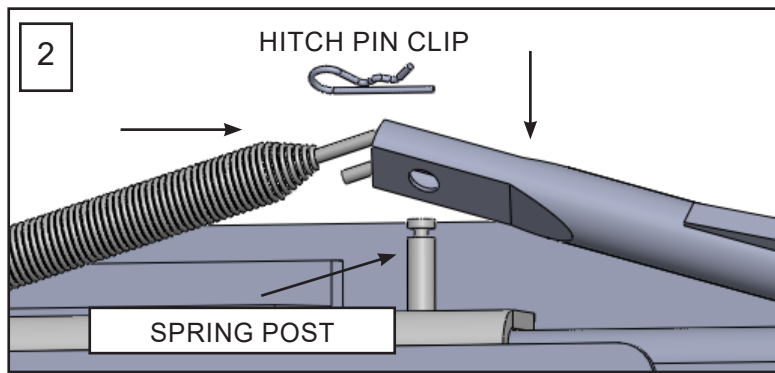

3. Bring the handle and spring down over the spring post and replace the hitch pin clip.

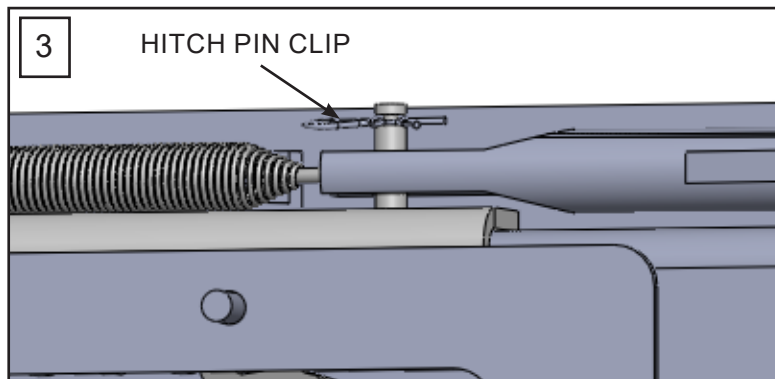

FIFTH WHEEL PLATE OPERATION

A better understanding of the plate's locking and un-locking operation can be obtained by viewing the working parts from the underside of the plate. The Fifth Wheel Plate can be removed and turned over to view the workings of the mechanism. When operating the Fifth Wheel Plate manually, please be aware that the Lock Jaw Assembly has more movement capability when there is not a king pin present to center the assembly. Refer to the illustrations below for part identification (#3601 plate pictured below).

1. To open the locking mechanism, lift and pull the Release Handle out until the Lock Catch engages the Lock Jaw Assembly (see illustrations on the next page)
2. As the trailer king pin moves into the plate, it will contact the Lock Lever, forcing the Lock Catch to disengage the Lock Jaw Assembly, allowing the Lock Bar Spring to close the Lock Jaw Assembly behind the King Pin. The King Pin must be fully engaged in the plate slot or the Lock Jaw Assembly will not seat properly, and the Handle Catch would not then engage the inner side wall of the plate. To be certain that the Lock Jaw Assembly has closed fully, attempt to pull the Release Handle without first lifting it.

NOTE: Please note that when lifting the handle to clear the side wall of the plate with the handle catch, it will be necessary to pull with some force to begin the Lock Jaw rotation. Merely lifting the Release Handle will not cause the Handle to "pop" open and rotate the Lock Jaw to the open position.

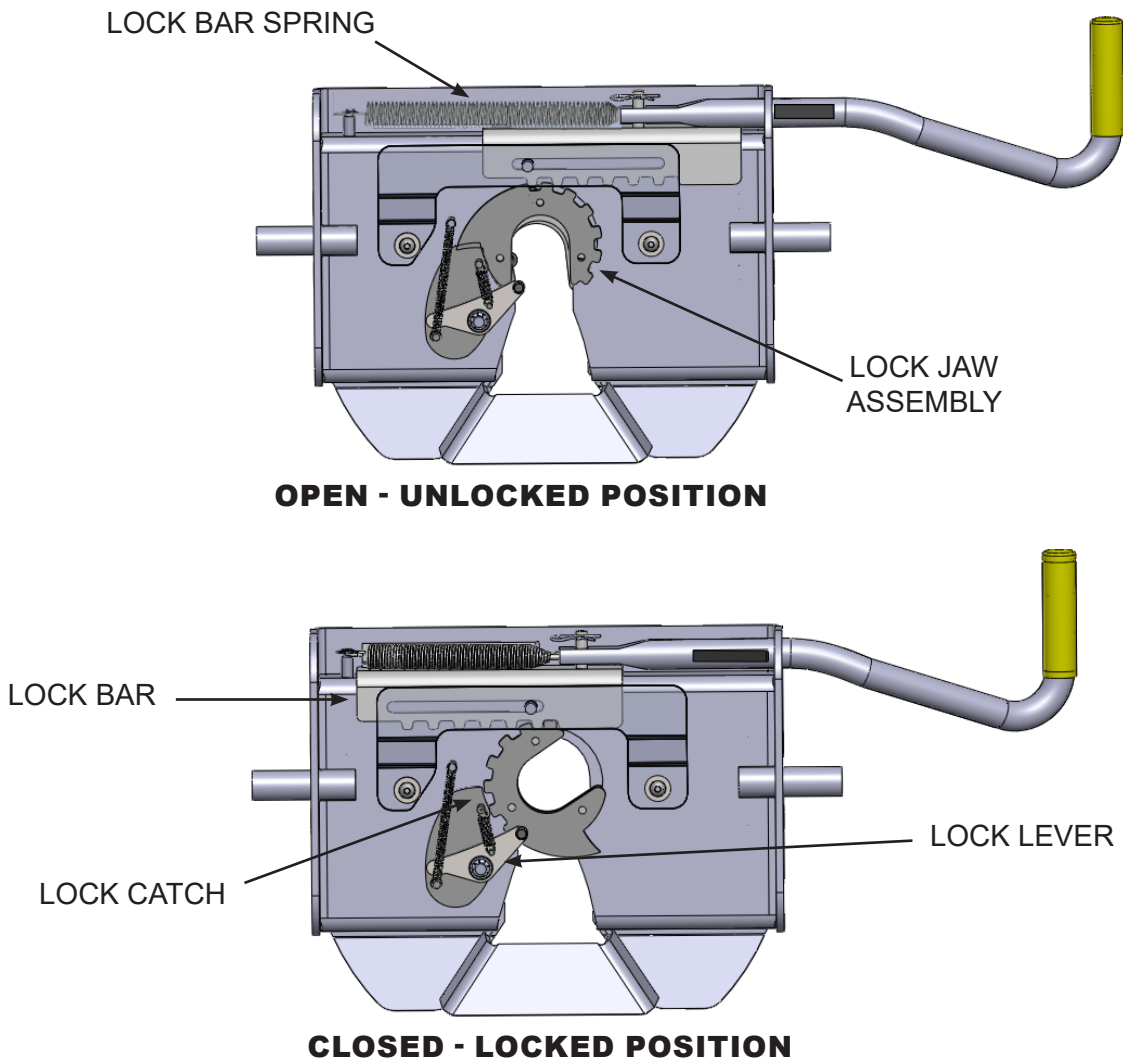

FIFTH WHEEL PLATE OPERATION

CAUTION: DO NOT ATTEMPT TO TRIP THE LOCK MECHANISM WITH YOUR HAND. USE A PROBE DEVICE TO SIMULATE THE KING PIN ACTION.

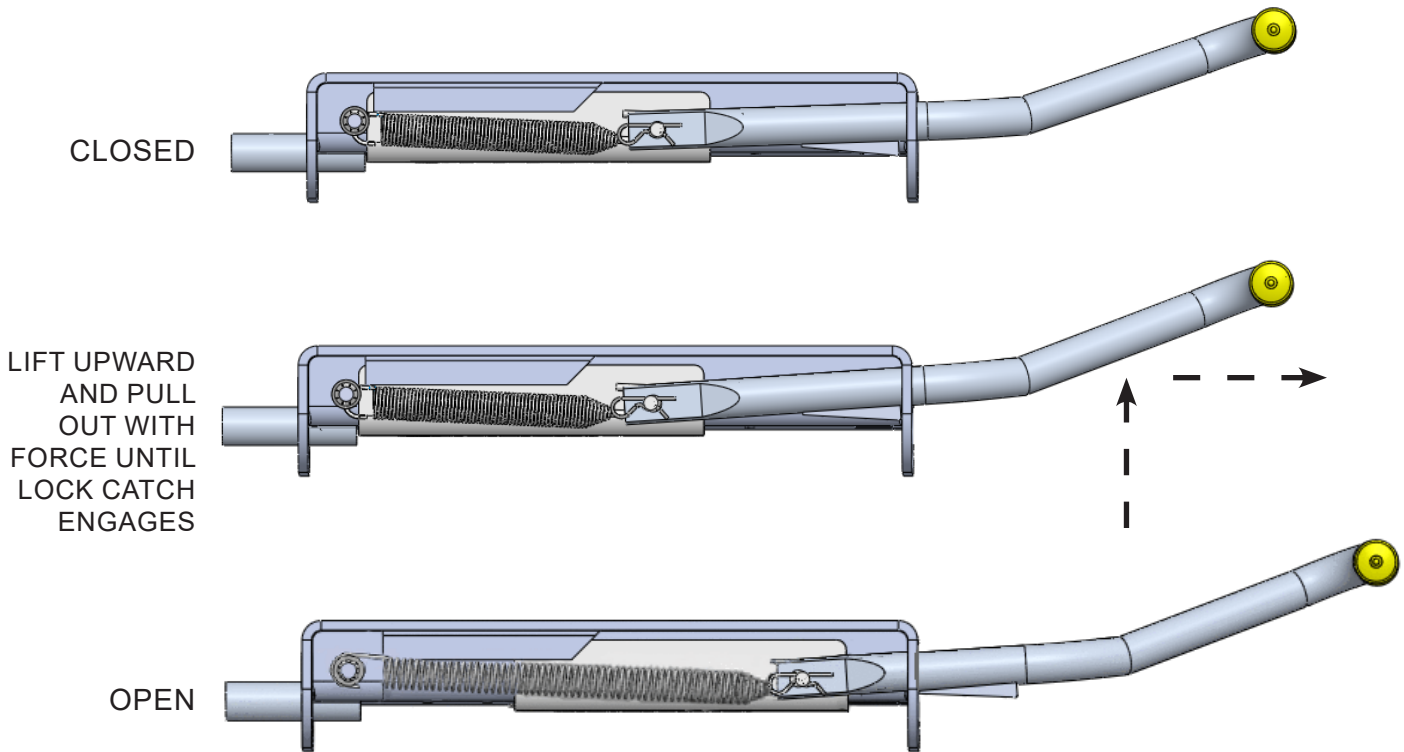

To discourage theft or pranksters, place a padlock through the obround hole above the Release Handle (see Illustration below).

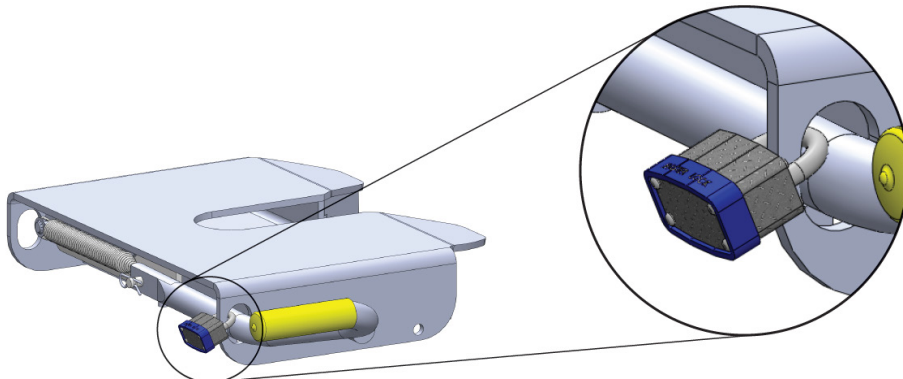

HITCH INSTALLATION

The OE Series SuperGlide hitch can only be installed on vehicles equipped with the GM Tow Prep Package.

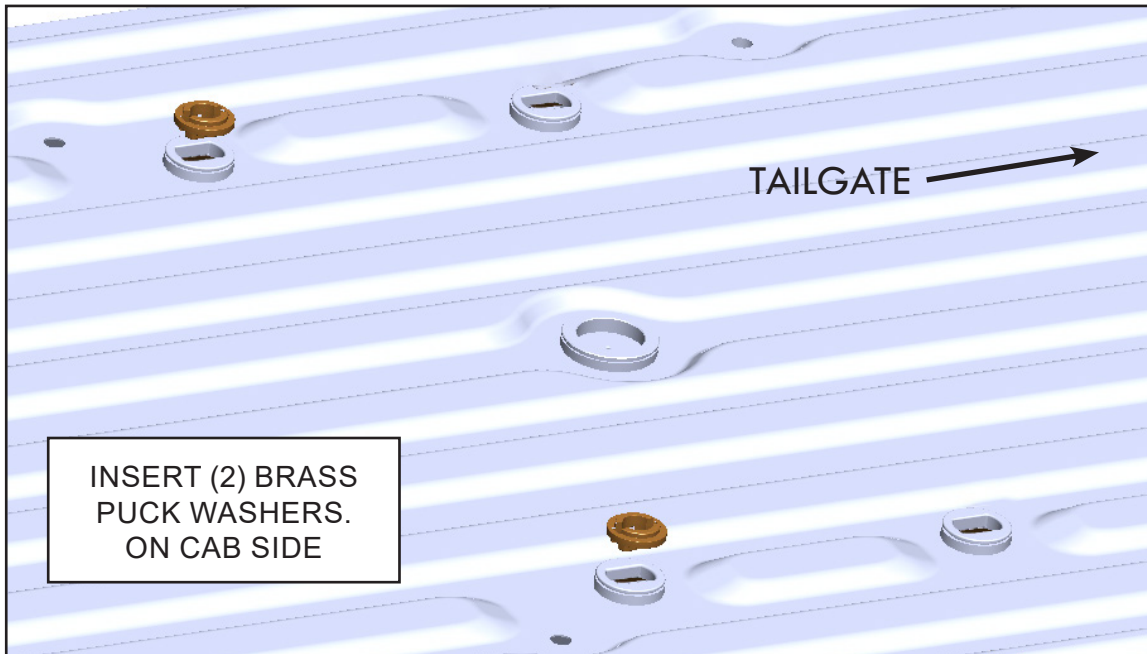

1. Place the (2) Brass Puck Washers into the OE pucks on the side closest to the cab, make sure to orient the Washer bosses facing downward.
2. Place the SuperGlide onto the pucks. Make sure that the hitch is fully seated on the Brass Puck Washers.

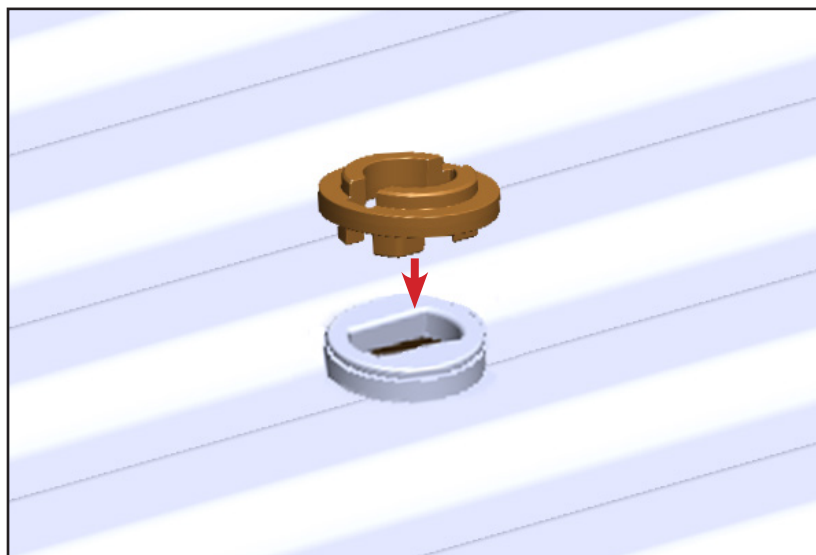

BUILD THE POST ASSEMBLY

Build the (4) post assemblies used for clamping the hitch to the bed of the truck. Note that the cross pin is factory set.

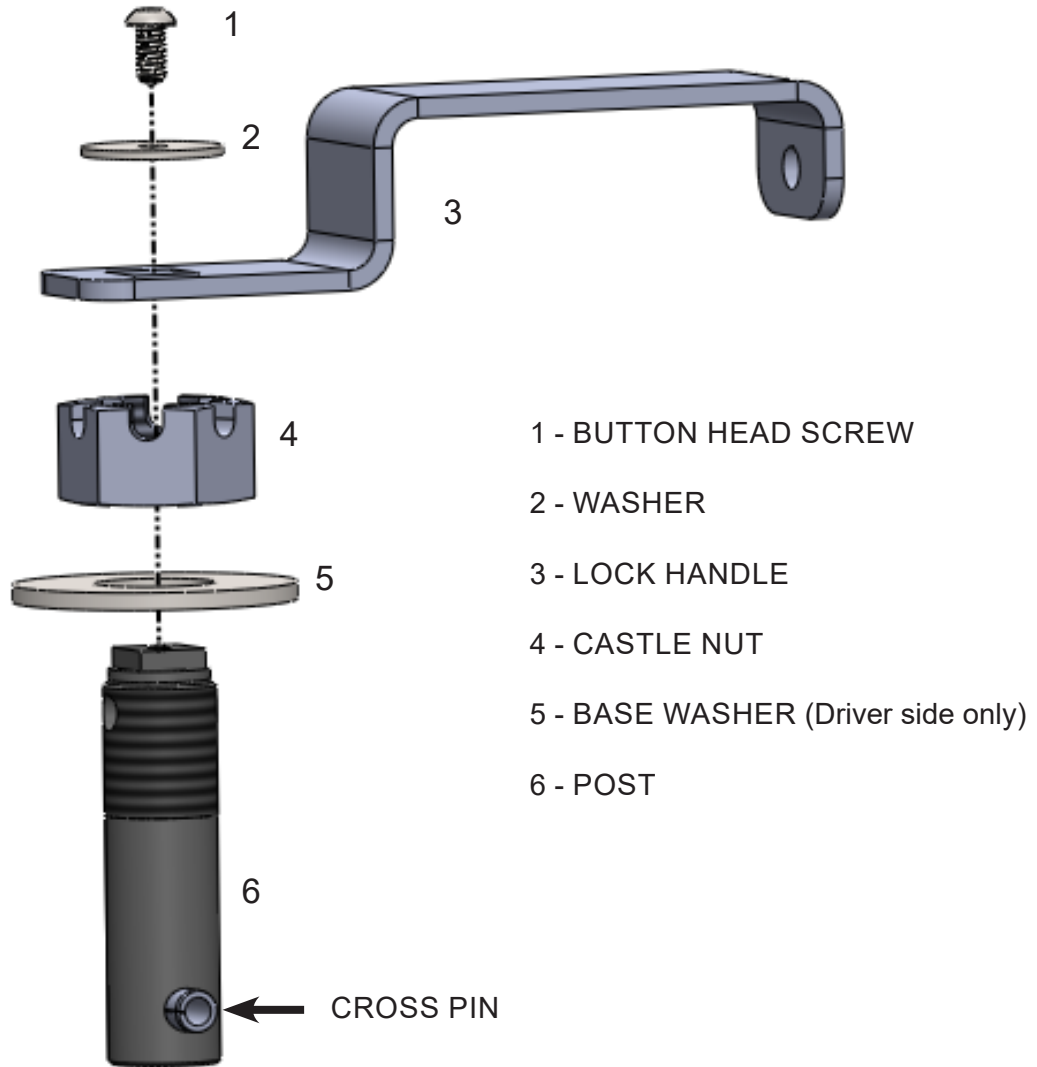

1. Place the Base Washer down on the Post (Driver side only).
2. Thread Castle Nut onto the Post.
3. Align the Lock Handle 90 degrees to the direction of the Cross Pin and place on top of the Post, the handle cut-out fits down over the square top on Post.
4. Add the Washer and Button Head Screw and tighten to 4 ft-lbs*.

*** WARNING:** This screw should be checked for tightness before each use, and also inspect the handle for proper seating on the post. This will insure that the post assembly will orient properly and safely secure the hitch to the truck bed.

MOUNTING POST INSTALLATION

Place the hitch post holes directly over the puck, you should be able to adjust hitch base so that each Mounting Post falls into place as you go. You may have to loosen the Adjustment Washers on the passenger side of hitch (see step 5).

NOTE: The rear posts (tailgate side) have larger cross pins than the front posts (cab side). The driver side posts have the washer under the castle nut, the passenger side does not have these due to Adjustment Washers.

1. Insert each Post Assembly handle into the hitch and orient as seen below (driver side shown below).
2. Rotate handles 90°. Posts may need to be adjusted (see next page).
3. Slide bail pins in through each lock tab and handle. A padlock can also be used here.
4. Repeat steps for the passenger side. Puck Adjustments Washers are present if posts are not easily inserted into the puck (see step 5).
5. Use a 1/2" Socket Wrench to loosen bolts and move Adjustment Washer plates until posts can be inserted.
6. Re-tighten bolts to 14 foot pounds.

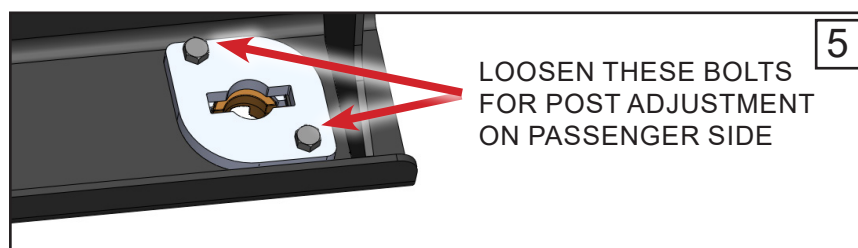
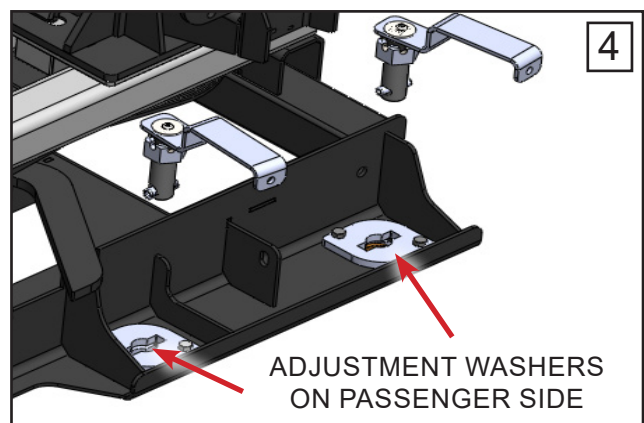
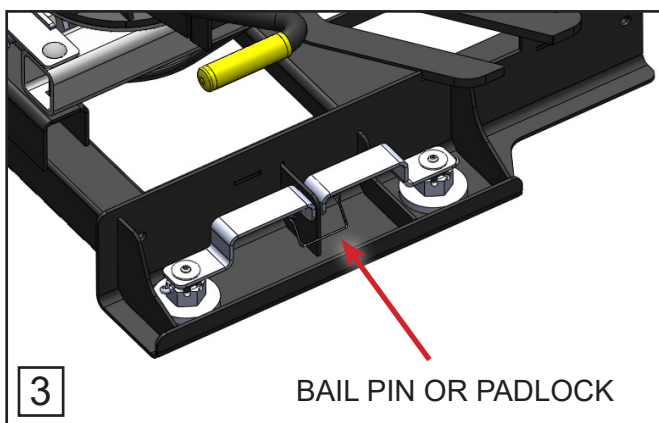
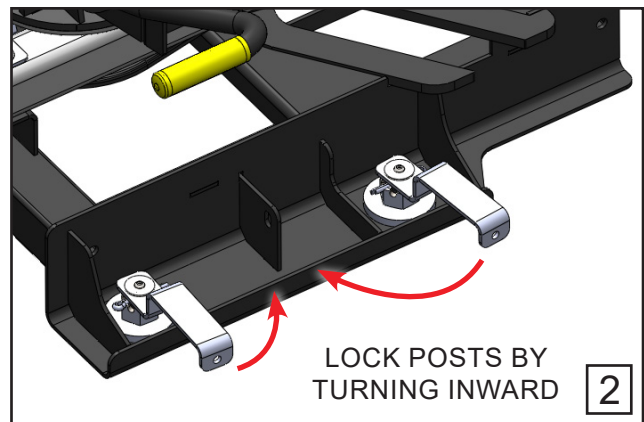
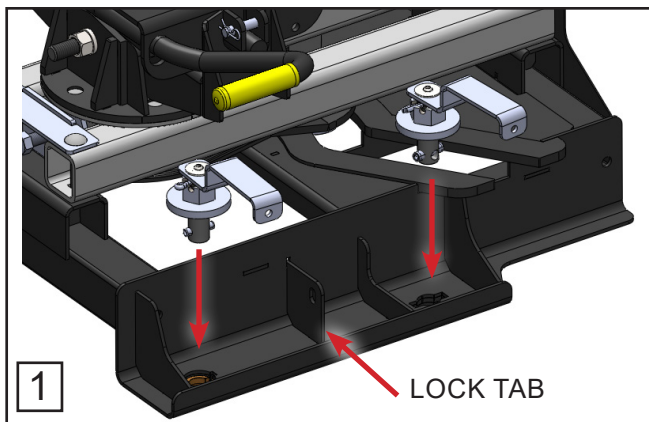

MOUNTING POST ADJUSTMENT

If the OE Series SuperGlide is loose on the mounting washer or the mounting post will not rotate while seated in the Puck, the Mounting Post is in need of adjustment. To adjust the Mounting Post, perform the following:

1. Remove the Cotter Pin from the Mounting Post Assembly.
2. Rotate the castle nut open until it is near the handle and then insert the assembly through the opening in the hitch base into the puck and rotate the handle to the closed position.
3. Next, lift up on the handle so that the top of the cross pin touches the bottom of the puck. Thread the nut down until it bottoms out against the hitch base.
4. Rotate the handle open and closed to test the tightness "feel", if the handle rotates with too much difficulty, then back off the castle nut one crenal and try it again. Likewise, if the handle rotation is too easy rotate the castle nut one additional crenal. Keep repeating this action until you have a snug fit.
5. Once you have a snug fit, remove the post assembly and insert the cotter pin. Bend the end of the cotter pin to secure the nut in the chosen position.
6. Re-latch the Mounting Handles as shown on the first page of Mounting Post Installation (Page 13).

NOTE: The Castle Nuts may require additional adjustment (tighter) after hitching for the first time and the hitch settles down on the Mounting Assembly.

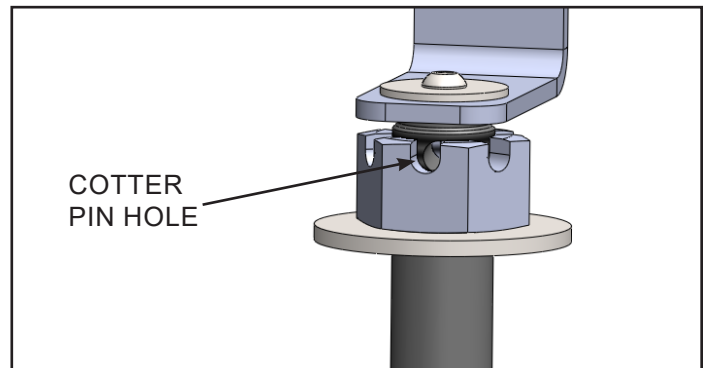
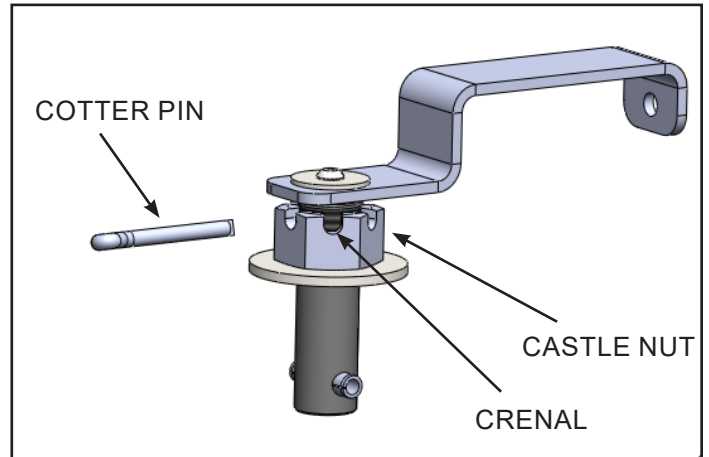

HITCHING

WARNING: Never perform any of the following actions while any part of a person is between the vehicle and trailer.

1. Block the trailer wheels in both directions.
2. Align your truck with the center of the trailer. The truck and trailer centerline must be within 10 degrees of each other.
3. Lower your tailgate and back up until there is about 6" of clearance between the SuperGlide hitch and the end of the Capture Plate (sold separately and installed on your trailer's king pin plate). Raise or lower the front of the trailer so the bottom of the Capture Plate is aligned slightly above the beginning of the ramp area of the Fifth Wheel Plate. This procedure will cause the front edge of the Capture Plate to "ride up" the ramp and flatten or tilt the hitch plate into a parallel position. Add WD-40 to the top of the hitch plate and bottom of the Capture plate and king pin to make hitching easier.

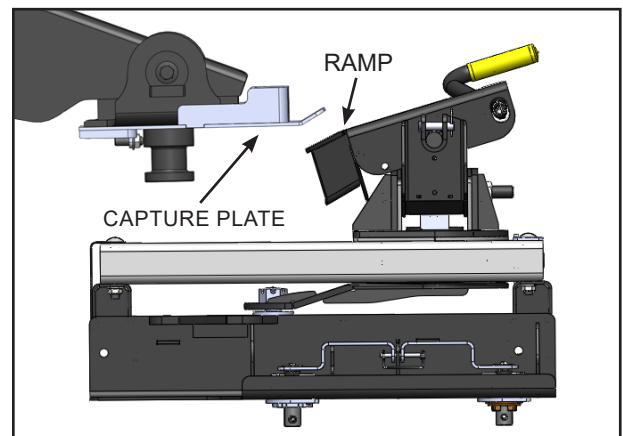
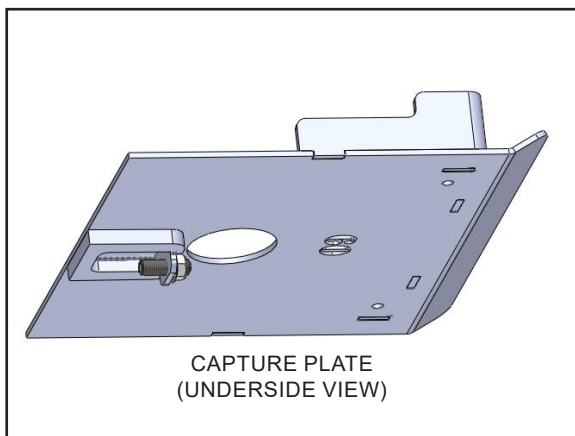

CAUTION: If this procedure is not followed, the king pin may bind in the plate mechanism and not lock-in properly. Following the procedure, as outlined in Step 3 will ensure that you will not "high hook" the king pin in the plate. "High hooking" occurs when backing your hitch into a trailer that is set too high, resulting in the lower flange of the king pin to wedge itself against the metal edge of the lower horseshoe piece or against the Lock Jaw Assembly. Damage to the Lock Jaw Assembly may result and not allow smooth operation of the closing mechanism.

4. The Fifth Wheel Latch must be in the open position (see illustration on page 10). Lift and pull out on the Release Handle to open the Lock Jaw Assembly.

CAUTION: Damage may result should you attempt to hook up with the Lock Jaw Assembly in the closed position.

5. Back up the truck in one fluid motion, so the king pin enters the center of the Fifth Wheel Plate opening.
6. Set your parking brake while the king pin is pressed against the hitch and you feel it stop the rearward roll of your truck.
7. Make sure the Lock Jaw Assembly is completely wrapped around the king pin.
8. Be sure that the Release Handle has fully returned to the closed position and proceed to Safety Checks (page 16).

SAFETY CHECKS

1. Shine a light on the Fifth Wheel Plate Lock Jaw Assembly making sure it has closed around the king pin.
2. Pull the Release Handle towards you without lifting it up. If the Lock Jaw Assembly is completely closed the Handle Catch will prevent you from being able to pull the Release Handle open.
3. Raise the trailer jack base plates just above the ground, lock your trailer brakes, then pull the tow vehicle slowly forward putting a strain on the trailer.
4. When you are assured that the trailer is safely hooked up, raise your trailer jacks into their full retracted position.

FAILURE TO PERFORM THESE SAFETY CHECKS MAY RESULT IN DAMAGES TO TRUCK AND TRAILER.

UNHITCHING

WARNING: Never perform any of the following actions while any part of a person is between the vehicle and the trailer.

1. Once you have the trailer located and are ready to unhitch, block the trailer wheels so it will not roll back or forward. Back into the blocked trailer slightly and set the parking brake while you are still in gear. This action will relieve pressure on the lock mechanism before attempting to release the latch mechanism.
2. Lower the trailer jacks to the point of just touching the ground but do not raise the trailer at this point.
3. Open the Lock Jaw Assembly by first lifting, then pulling the Release Handle towards you (see pages 9 & 10).
4. Lower the trailer jacks until the bottom of the king pin box is almost free of the top of the Fifth Wheel Plate. Make certain that the bottom of the king pin is not so high that binding on the hitch Lock Catch would result.
5. After lowering the truck's tailgate, disconnect the trailer electrical cord and break-away switch cable, then pull forward.
6. As the king pin slides from the Fifth Wheel Plate, notice that the locking mechanism remains open once the king pin is removed.

CAUTION: If it should be necessary to reposition your trailer, you must follow the hitching procedures to ensure the hitch is latched before moving the trailer.

CAUTION: You may wish to keep the plate closed until you are ready to re-hitch to avoid injury or accidents to children or adults who attempt to operate the plate mechanism. **DO NOT ATTEMPT TO TRIP THE LOCK MECHANISM WITH YOUR HAND, USE A PROBE TO SIMULATE THE KING PIN.**

ADJUSTING THE TURNTABLE CAM ARM ASSEMBLY

This adjustment will need to be made periodically. If you are experiencing a bump or “clunk” when starting or stopping, or if the hitch is sliding up and down the way tubes when you are not hooked up to the trailer you can perform this adjustment to reduce the noise and keep the hitch in the forward towing position when not trailering.

1. The Turntable Cam Arm Roller needs to be kept snug against the rear edge of the of the Cam Slot (see below).
2. To adjust, loosen the Jam Nut located on the Threaded Stop Assembly, under the Fifth Wheel Plate (on the side facing the front of your truck).
3. Adjusting the Threaded Stop Assembly’s hex-shaped plate, will remove excessive play from between the Low Friction Polymer Wear Plates and the Turntable Cam Arm Roller.
4. Turn the hex-shaped plate of the Threaded Stop Assembly by hand, adjusting incrementally, until resistance is felt when pulling the Turntable Cam Arm Assembly aligned straight from front to back. While holding the hex-shaped plate in place, tighten the Jam Nut with a wrench. The Cam Arm Assembly should be tight enough on Threaded Stop Assembly that you can barely move it by hand.

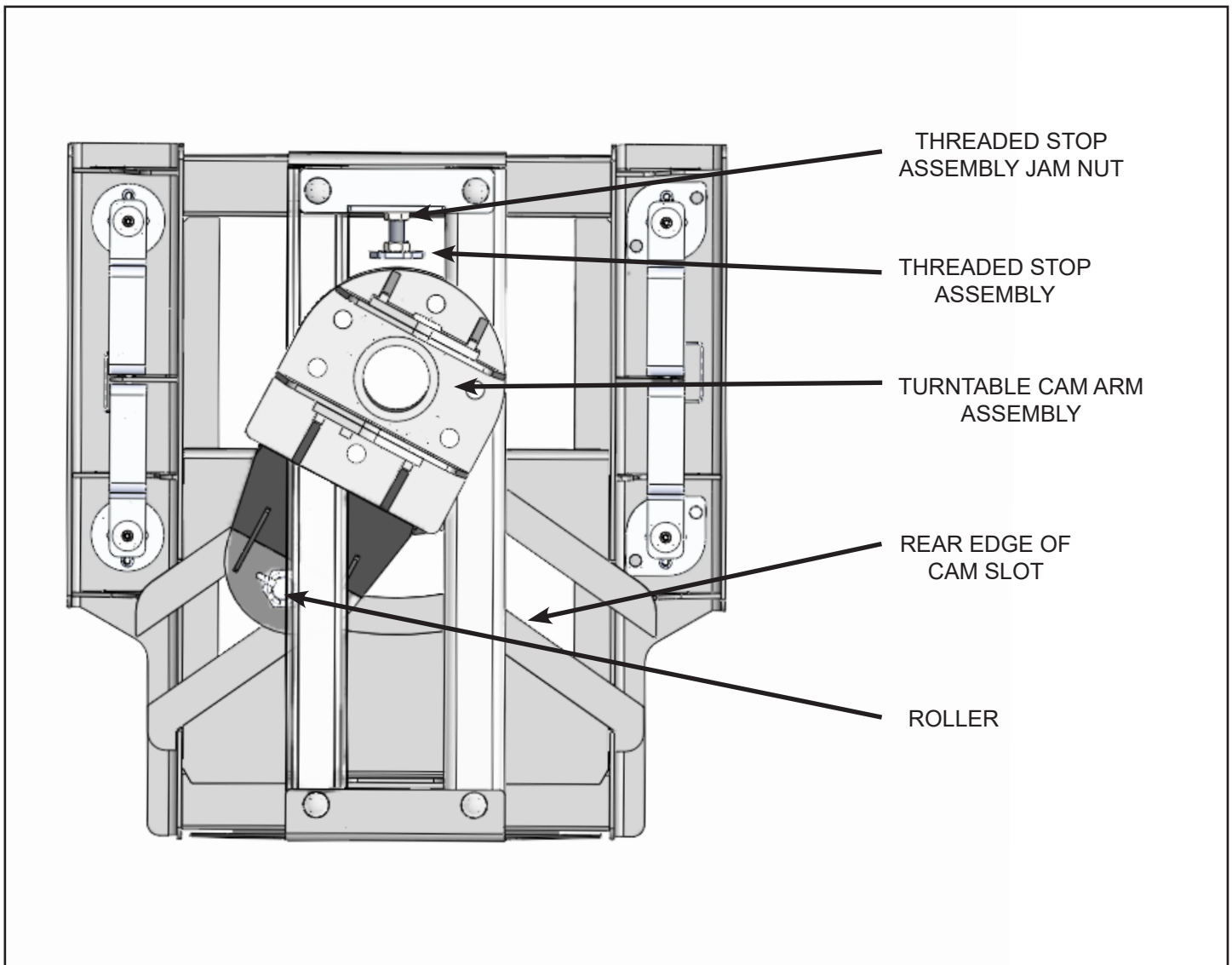

CHALLENGE VS. SOLUTION

CHALLENGE	SOLUTION
Cannot open the Release Handle.	You may have too much rearward pressure against the lock mechanism. Back your truck slightly to relieve pressure and set your parking brake before shifting to park. Continue with the un-hitching procedures.
The latch handle mechanism seems too stiff to operate.	Spray the locking mechanism with WD-40. Work the handle until it slides freely. If the problem persists, you may need to degrease and re-lube all working parts.
I need to have a professional evaluate OE Series SuperGlide.	Contact PullRite's Customer Service Dept. at (800) 443-2307. Your needs will be assessed and resolved by PullRite or you will be directed to an authorized PullRite Service Center.
Hitch seems loose on the Mounting Posts.	You may need to adjust them. Refer to the "Mounting Post Adjustment" section (page 14).
The Mounting Posts will not rotate into the "locked" position.	You may need to adjust them. Refer to the "Mounting Post Adjustment" section (page 14).

NOTE: Most challenging issues can be solved with the use of lubrication such as WD-40 on moving parts (or a graphite based spray like Slip Plate when the application is metal-to-metal).

FREQUENTLY ASKED QUESTIONS

1. Can I pull other Fifth wheel trailers with my SuperGlide hitch?

Your SuperGlide hitch can only pull trailers equipped with the SuperGlide Capture Plate. If you hook up to a trailer that does not have a Capture Plate installed, there is no control to keep the hitch in the forward towing position and the weight of the trailer will cause the head to turn and slam or “free fall” to the rear of the hitch’s angled cam slot, which may cause damage to the hitch, truck, and the king pin. We do not recommend locking the hitch in any way to keep it in the forward position.

2. Will a standard hitch be able to tow my trailer with the Capture Plate installed?

The Capture Plate will need to be removed from the pin box before a standard fifth wheel hitch can tow your trailer. If the plate is not removed, the king pin will not rotate in the hitch and damage will result to the Capture Plate and conventional hitch. Most of Pullrite capture plates are easily removed, If however, you cannot remove the Capture plate, part # 3336 is a conversion adapter that will allow a standard fifth wheel hitch to tow your trailer with the Capture Plate installed. The adapter is used in conjunction with your Fifth Wheel Plate, or “head” of the SuperGlide.

3. Is there a cover available for my SuperGlide hitch?

Please contact Customer Service at (800) 443-2307 for availability..

4. How much does my SuperGlide weigh?

The #4500 weighs 209 lbs. Lifting weight with the Head Plate removed is 169 lbs.

5. Can I leave the hitch attached to my trailer and use the trailer jacks to lift the hitch out of the truck?

Yes, you can use the trailer jacks to lift the hitch out of the truck. The hitch should not be left hanging from the king pin. Once you have the hitch lifted out of the truck you should have a stand available to lower the hitch onto for storage.

6. Can I hook up or unhook at a 90 degree angle?

Hooking up can only be accomplished when the truck and trailer are aligned within 10 degrees of each other. See “Hitching” (page 15). for more information on hooking up. Unhooking by pulling the release handle can only be accomplished when the truck and trailer are aligned within 10 degrees of each other.

In emergency situations you can pull the clevis pins and clips that attach the Fifth Wheel Plate or “head” assembly to the Rocker Arm, lower your landing gear and raise the trailer up until the Fifth Wheel Plate is free from the Rocker Arm. Pull forward from under the parked trailer. At that point you can pull the Release Handle, remove the head from the king pin and reattach it to your hitch with the clevis pins and clips.

7. Can I use a Teflon disc or lube plate on the king pin plate?

The king pin box and SuperGlide plate or “head” move together and since there is no friction, there is no need for any grease or a lube plate. Use of a Teflon disc or lube plate would cause the king pin to be too short and problems hooking up will occur.

EXPLODED VIEW

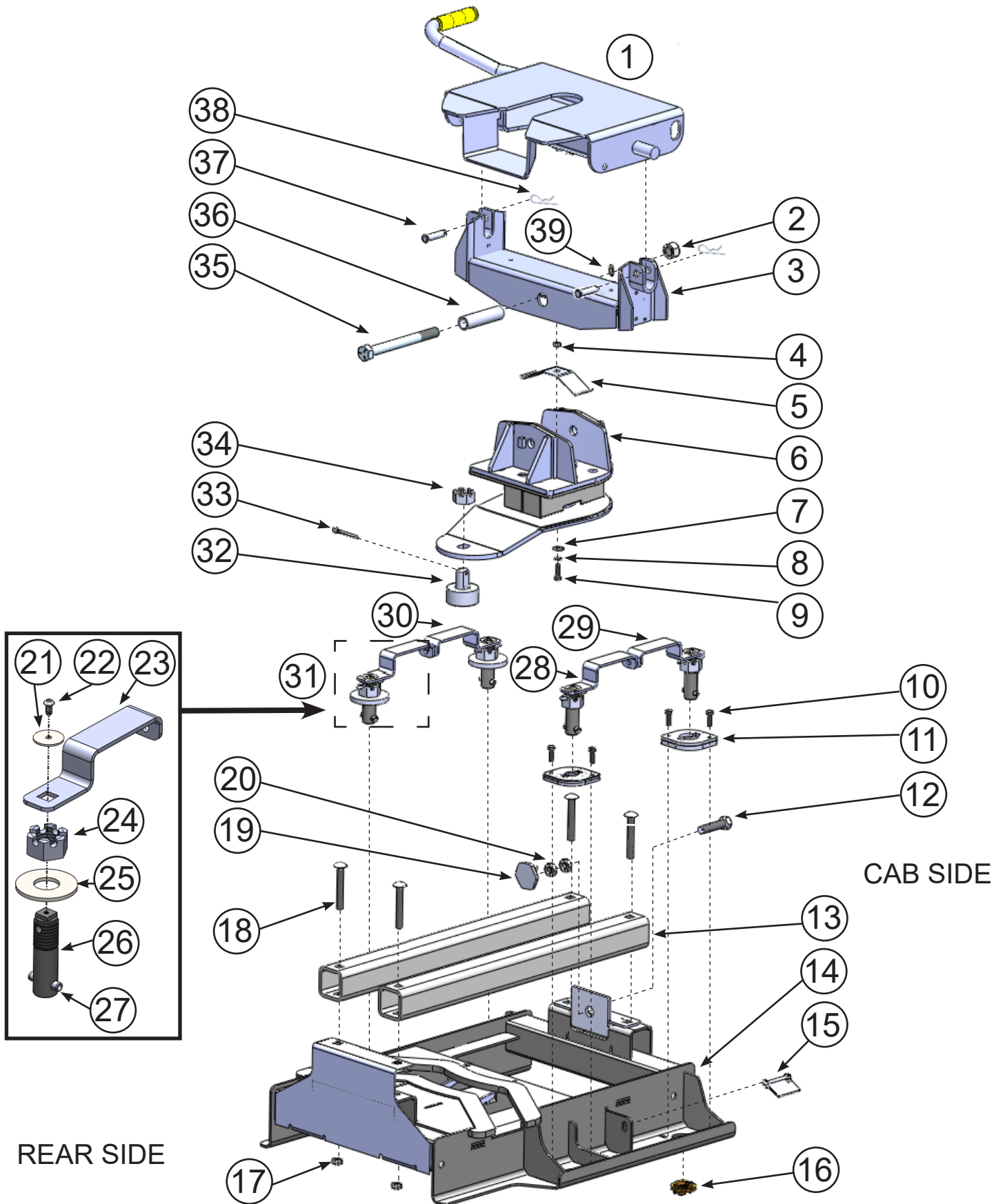

#4500 PARTS LIST

ITEM	DESCRIPTION	PART NO.	QTY	MATERIAL
1	FIFTH WHEEL PLATE ASSEMBLY	3601	1	
2	ROCKER ARM NUT	98150131	1	3/4"-10 Hex Nut Zinc Plated
3	ROCKER ARM	3302	1	
4	ROCKER ARM SPRING NUT	98410161	1	5/16"-18 Low Pilot Height Weld Nut
5	ROCKER ARM SPRING	35100001	1	
6	CAM ASSEMBLY	4503	1	
7	ROCKER ARM SPRING WASHER	98250160	1	5/16" FLAT WASHER
8	ROCKER ARM SPRING LOCK WASHER	98200159	1	5/16" LOCK WASHER
9	ROCKER ARM SPRING BOLT	98010244	1	5/16"-18 X 1" Grade 5 Zinc Plated
10	5/16" ADJUSTMENT BOLT	98010244	4	5/16"-18 X 1" Grade 5 Zinc Plated
11	PASSENGER'S SIDE ADJUSTING WASHER	45070202	2	
12	STOP PLATE BOLT	98010219	1	5/8"-11 X 2 1/2" TAP Bolt Zinc GR 5
13	WAY TUBES	29060001	2	
14	4500 HITCH BASE	4506	1	
15	BAIL PIN	98410529	2	
16	BRASS MOUNTING WASHER	15070001	2	
17	1/2"-13 SERRATED FLANGE NUT	98150201	4	1/2"-13 Serrated Flange Nut Zinc
18	WAY TUBE CARRIAGE BOLT	98050113	4	1/2"-13 x 3.5" Carriage bolt
19	STOP PLATE	44050101	1	
20	STOP PLATE JAM NUT	98150122	2	5/8"-11 Hex Jam Nut
21	FLAT WASHER	98250150	2	1/4" Oversized Flat Washer
22	1/4" BH SOCKET CAP SCREW	98410241	2	1/4-20 X 1/2" BH Socket Cap Screw
23	POST HANDLE	15040601	4	
24	FOOT POST CASTLE NUT	98150121	4	1"-14 Slotted Castle Nut
25	DRIVER SIDE POST WASHER	45070101	2	
26	OE FOOT POST	44480701	4	
27	SPRING PIN	98410524	1	3/8" X 1 3/4" Slot Spring Pin
28	PASSENGER REAR POST ASSEMBLY	450704	1	
29	PASSENGER FRONT POST ASSEMBLY	450702	1	
30	DRIVER FRONT POST ASSEMBLY	450701	1	
31	DRIVER REAR POST ASSEMBLY	450703	1	
32	ROLLER	23040002	1	
33	COTTER PIN	98410567	1	1/4" X 2" Cotter Pin Zinc Plated
34	ROLLER CASTLE NUT	98150121	1	1"-14 Slotted Castle Nut
35	ROCKER ARM BOLT	98010148	1	3/4-10 X7.5 HCS GR 5
36	LATERAL PIVOT SLEEVE	33020104	1	
37	CLEVIS PIN	98410111	2	1/2" X 2" Clevis Pin Zinc Plated
38	HITCH PIN CLIP	98410127	2	ZINC PL #3 Hitch Pin Clip
39	ROCKER ARM LOCK WASHER	98200124	1	3/4" Lock Washer

5 YEAR LIMITED WARRANTY

PULLIAM ENTERPRISES, INC. hereinafter referred to as "PULLIAM", warrants to the first retail owner only, this PullRite towing system to be free from defects in materials and workmanship for a period of five (5) years or 31,068 miles (50,000 km) after the installation on purchaser's vehicle, whichever occurs first.

To validate this warranty, the first retail owner must mail the provided warranty card to PULLIAM, or register online at www.pullrite.com, within ten (10) days after installation of said towing system on his vehicle.

The owner is responsible for all normal and preventative maintenance described in the Owner's Manual.

If any defect occurs which the owner believes is covered by this warranty within said five (5) year period, the owner shall contact PULLIAM immediately, either in writing or by telephone call, Attention Customer Service Department. The owner will be instructed to return the hitch at his expense either to an authorized PullRite dealer or to PULLIAM to repair or replace any parts necessary to correct defects in material or workmanship.

Repair or replacement shall be at the sole option of PULLIAM and shall be completed by or on behalf of PULLIAM free of charge for materials and labor.

This warranty gives you specific legal rights, and you may also have other rights which vary from state to state.

THIS WARRANTY SPECIFICALLY *EXCLUDES* EACH OF THE FOLLOWING:

1. Defects in the product resulting from misuse, neglect, accident, loading beyond the vehicle's capacity, failure to comply with instructions contained in the Owner's Manual or unauthorized repairs, replacements, alterations or modifications. "Unauthorized repair, replacements, alterations" are those made without PULLIAM'S prior knowledge and consent.
2. Any incidental or consequential damage including, but not limited to, loss of use of the vehicle, towing charges, vehicle rental, loss of time, inconvenience, travel, gasoline, lodging and telephone expenses, loss of revenue and damages on account of personal injury and property damage. (Some states do not allow the exclusion or limitation of incidental or consequential damages, so these limitations may not apply to you).
3. Repairs or replacements of defects in any PullRite towing system, or part thereof, installed on any vehicle which has been rented, leased or used for any commercial purpose.
4. Any representation, warranty of undertaking made by any dealer or third party beyond the scope of the warranty herein expressed.
5. Any problem resulting in normal deterioration due to wear or exposure.

TO THE EXTENT PERMITTED BY LAW, IMPLIED WARRANTIES OF MERCHANTABILITY AND FITNESS FOR A PARTICULAR PURPOSE ARE LIMITED IN DURATION TO FIVE YEARS FROM THE DATE OF INSTALLATION ON THE FIRST OWNER'S VEHICLE. (SOME STATES, HOWEVER, DO NOT ALLOW LIMITATIONS AS TO DURATION OF IMPLIED WARRANTY, SO THOSE LIMITATIONS MAY NOT APPLY TO YOU)



Product Warranty Registration

As an owner of a PullRite product, you must register your product to be considered for warranty coverage. See Owners Manual for further details.

Please note, that you can also register online at www.pullrite.com/warranty.htm.

Name: _____

Address: _____

City: _____ State: _____ Zip: _____

Email Address: _____

Phone (optional): _____

Purchase Price: _____ Date of Purchase: _____

Dealer's Name: _____

Dealer's Address: _____

Dealer's City: _____ Dealer's State: _____ Dealer's Zip: _____

Dealer's Phone: _____

Model Purchased: _____

Vehicle Make: _____ Vehicle Model: _____ Vehicle Year: _____

Vehicle Year: _____ Vehicle Cab Style: _____ Vehicle Bed Length: _____

Did you receive an Owners Manual from the Dealer? Yes / No

What influenced you to buy your hitch? _____

Comments:



MANUFACTURED BY:

PULLIAM ENTERPRISES, INC.
13790 East Jefferson Blvd.
Mishawaka, IN 46545
(574) 259-1520 • (800) 443-2307
info@pullrite.com • www.pullrite.com