



OE SERIES

by 

Gooseneck OWNER'S MANUAL

for Ford and Dodge Tow Prep Kits



#4436 30K OE Series Gooseneck Ball

Gross Trailer Weight (Maximum) 30,000 lbs.
Vertical Load Weight (Max. Pin Weight) 7,500 lbs.



#4438 30K OE Series Premium Gooseneck Chromed Ball w/ Plate, locking pin & storage case

Gross Trailer Weight (Maximum) 30,000 lbs.
Vertical Load Weight (Max. Pin Weight) 7,500 lbs.



#4437 30K OE Series Gooseneck Ball w/ Plate

Gross Trailer Weight (Maximum) 30,000 lbs.
Vertical Load Weight (Max. Pin Weight) 7,500 lbs.

The following instructions provide valuable information regarding the function and proper use of the OE Series Fifth Wheel Towing System. Patent Pending.

YOU MUST COMPLETELY READ THE INSTRUCTIONS WITHIN THIS MANUAL, PRIOR TO OPERATING THE HITCH TO PREVENT UNNECESSARY DAMAGE TO THE HITCH, VEHICLE, OR TRAILER.

For more information, please call PullRite at (800) 443-2307.

TABLE OF CONTENTS

| | |
|--|---|
| SYSTEM WEIGHT RATING vs. COMPONENT WEIGHT RATING | 3 |
| LUBRICATION..... | 3 |
| GOOSENECK BALL & HITCH PIN | 3 |
| ANNUAL MAINTENANCE..... | 3 |
| HITCHING | 4 |
| SAFETY CHECKS..... | 4 |
| GOOSENECK BALL INSTALLATION..... | 5 |
| PARTS SECTION..... | 6 |
| ILLUSTRATION — EXPLODED VIEW | 6 |
| PARTS LIST | 7 |

SYSTEM WEIGHT RATING vs. COMPONENT WEIGHT RATING

A towing system includes each vehicle and component involved in towing. Each item in your towing system has a capacity or weight rating. Your trailer has a Gross Vehicle Weight Rating, or GVWR. Your truck has a tow capacity, payload capacity, and possibly more. In addition, your gooseneck hitch has a weight rating. This weight rating must be at, or above, the GVWR of your trailer for you to tow safely. In addition, if your truck can tow larger loads (has a larger capacity) than the rating of your hitch, your system is only safe to tow loads at the lower rating, that of the hitch.

Your mounting kit also has a weight rating, just like your gooseneck hitch. Many times, these rating are designed to match. But, this is not always the case. Your mounting kit may be higher rated than your gooseneck hitch, but it also could be lower depending on the components involved. **The lowest rating of any one component in the system becomes the rating of the entire system.** If your mounting kit is rated to 18,000 lbs., and your hitch is rated at 24,000 lbs., the weight rating of the entire system will not be above 18,000 lbs. Other components in the system could lower the actual system rating further.

It is the end users responsibility to ensure a safe towing experience. To this end, it is your responsibility to ensure that the truck, trailer, hitching components, and all other items involved are rated or have a capacity sufficient for the loads involved.

LUBRICATION

DO NOT OPERATE HITCH UNTIL YOU READ THIS SECTION!

The internal mechanism of the Gooseneck Ball should be lubricated with a light lubricant such as WD-40 or 3-in-1 oil, from bottom side of the Gooseneck Ball as needed. Be sure the gooseneck ball is free of dirt and old grease buildup. Lock and unlock the Gooseneck Ball repeatedly so that the lubricant will spread among the moving parts that may not have otherwise been covered sufficiently.

GOOSENECK BALL & HITCH PIN

Be sure the trailer's gooseneck coupler is clean and free from rust. A light coating of axle grease or other similar lubricant should be used on the Gooseneck Ball. Inspect and lubricate the Gooseneck Ball monthly with axle grease when heavily used. A light coating of lubricant on the hitch pins will help you install and reinstall them easily.

ANNUAL MAINTENANCE

Inspect all mounting bracket and hitch hardware, that it is securely fastened. Inspect all mounting bolts for tightness and general condition. The Gooseneck Ball should be removed and inspected, checking all moving parts for wear—clean as directed above. When storing your Gooseneck Ball, you should be sure that the Gooseneck Ball parts are lubricated with WD-40 to retard the formation of rust. Cover the entire assembly to prevent accumulation of dirt, grime, or rust.

HITCHING

WARNING: Never perform any of the following actions while any part of a person is between the vehicle and trailer.

1. Align your truck with the center of the trailer. The truck should be close to parallel to the centerline of the trailer.
2. Block the trailer wheels so the trailer will not roll back.
3. Lower your tailgate and back up until the gooseneck coupler is right over the Gooseneck Ball. Lower the front of the trailer so that the trailer's coupler locks onto the Gooseneck Ball.

SAFETY CHECKS

1. Check vehicle, Gooseneck Ball and gooseneck coupler for signs of wear or damage. Ensure that the gooseneck coupler opens, closes, and the handle springs close when released. (Always replace bent, broken, or worn parts before using this product.)
2. Most states require safety chains to be used. Make sure that the trailer safety chains are properly connected to the chain plate at the gooseneck ball and trailer.
3. Connect all trailer lighting and check that it is hooked up properly and is in good working order.
4. When you are assured that the trailer is safely hooked up, raise your trailer jacks into their full retracted position.
5. Check your coupler or trailer's owners manual for correct operation and additional safety checks.

FAILURE TO PERFORM THESE SAFETY CHECKS MAY RESULT IN DAMAGES TO TRUCK AND TRAILER.

GOOSENECK BALL INSTALLATION

NOTE: OE Series Goosenecks can only be installed on vehicles equipped with a factory Tow Prep Package.

1. Place the OE Gooseneck Ball {A} into the Gooseneck Puck, making sure the Gooseneck Ball is in the unlock position (the flats are not aligned with each other). To unlock the Gooseneck Ball hold the Gooseneck Ball Post {F} and rotate Gooseneck Ball counter-clockwise.
2. Lock the Gooseneck Ball to the Gooseneck Puck. Hold the Gooseneck Ball Post and rotate Gooseneck Ball clockwise. The “flats” on the Gooseneck Ball should now be aligned.
3. If a Chain Plate {B} is required in your area, place the Chain Plate over the Gooseneck Ball at this time. A plastic trim ring may have to be removed for proper fit.
4. Secure the Gooseneck Ball to the Gooseneck Ball Puck. Install the Hitch Pin {D} through the Gooseneck Ball and lock it in with the Pin Clip {E}. If you have the Premium Kit, Pin Clip {E} can be replaced with the included padlock.
5. Installation is complete. Since most safety chains are located rear of the coupler, rotate the chain plate so that the “ears” of the chain plate face vehicle *rearward*. Before operating, apply grease to the ball.

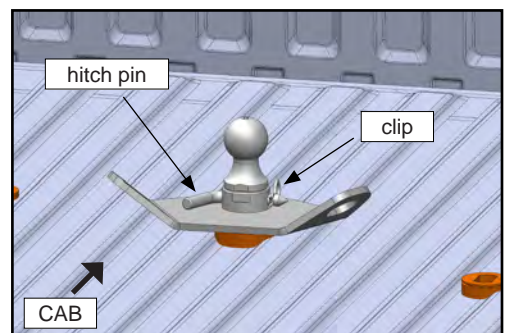
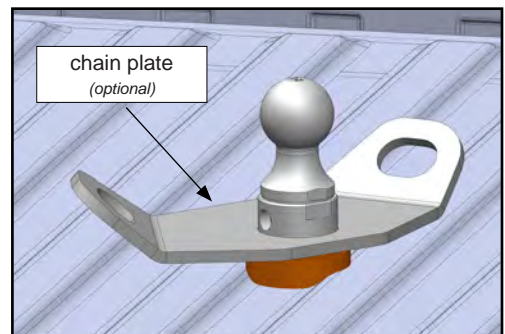
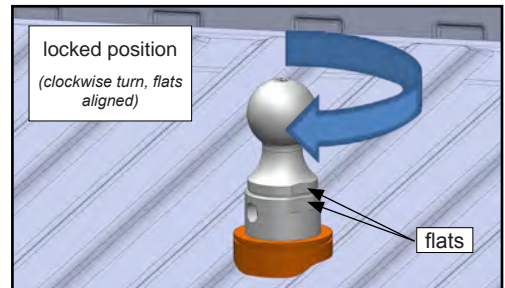
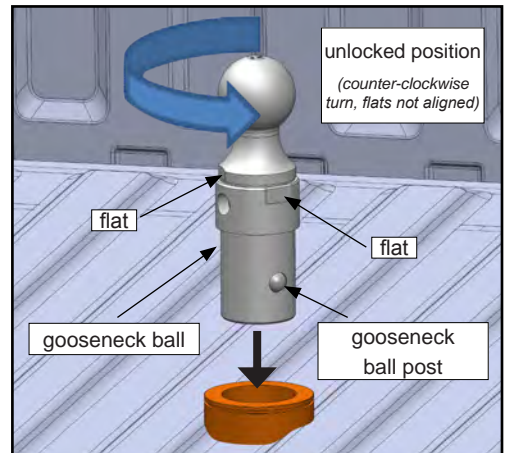
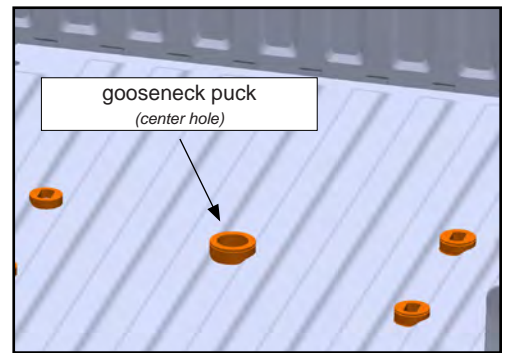

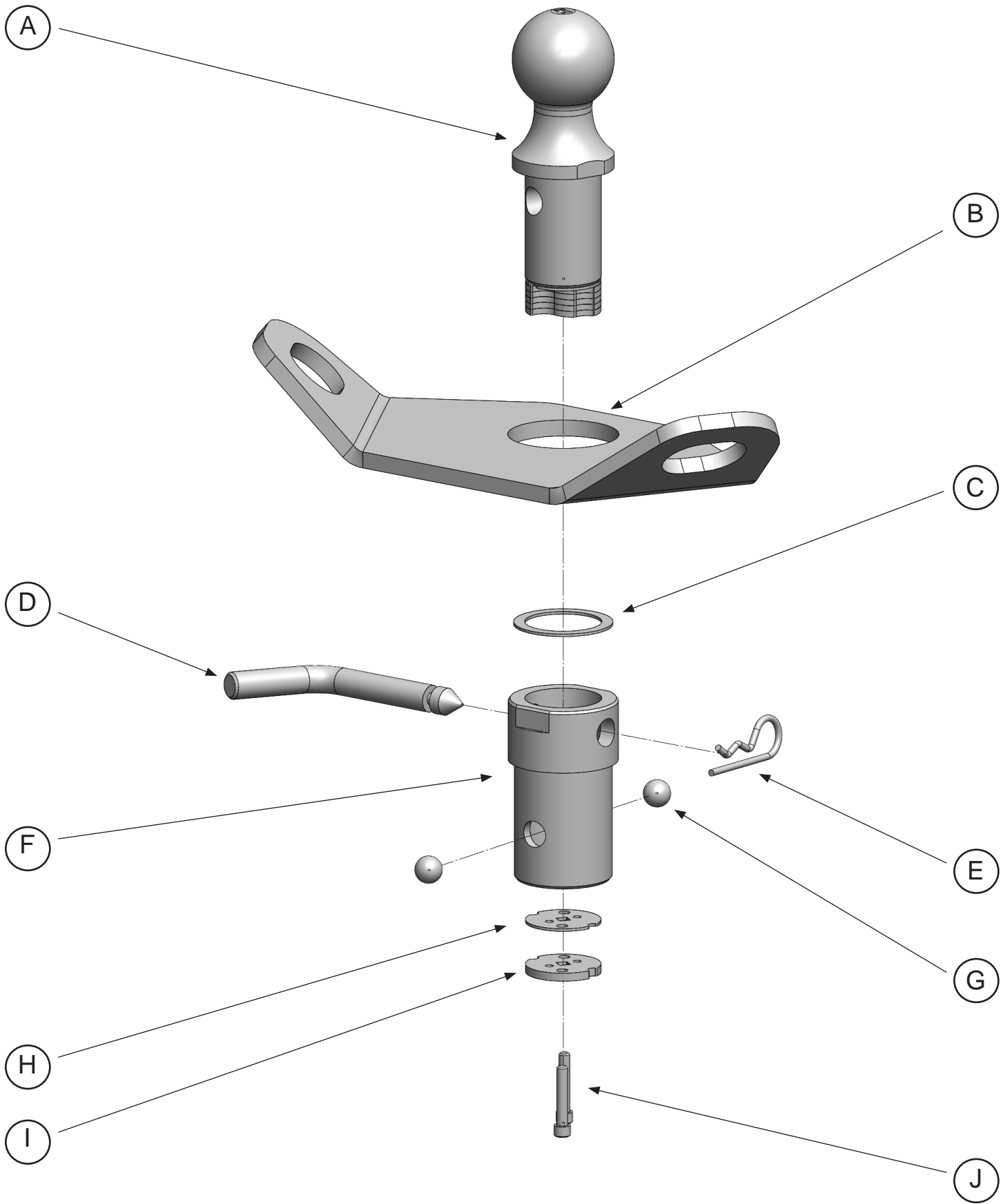

PARTS LIST

| ITEM | DESCRIPTION | PART NO. | QTY. | MATERIAL |
|------|-----------------------------|----------|------|--|
| A | OE GOOSENECK BALL | 443602 | 1 | |
| B | CHAIN PLATE | 44360101 | 1 | <i>(included in #4437 & #4438 kits only)</i> |
| C | BALL WASHER | 44360102 | 1 | |
| D | HITCH PIN | 010311 | 1 | 5/8" HITCH PIN |
| E | PIN CLIP | 98410143 | 1 | #9 PIN CLIP |
| F | GOOSENECK BALL POST | 44360301 | 1 | |
| G | BEARING BALL | 98410569 | 2 | |
| H | CAM LAMINATION PLASTIC | 44350101 | 1 | |
| I | CAM LAMINATION BOTTOM PLATE | 44350103 | 1 | |
| J | LONG CAP SCREW | 98410235 | 2 | 1/4"-20 X 3/8" |

NOTE: #4438 Premium Kit (not pictured) includes a chromed gooseneck ball and chain plate, hitch pin and lock, and a custom plastic carrying case.

5 YEAR LIMITED WARRANTY

PULLIAM ENTERPRISES, INC. hereinafter referred to as "PULLIAM", warrants to the first retail owner only, this PullRite towing system to be free from defects in materials and workmanship for a period of five (5) years or 31,068 miles (50,000 km) after the installation on purchaser's vehicle, whichever occurs first.

To validate this warranty, the first retail owner must mail the provided warranty card to PULLIAM, or register online at www.pullrite.com, within ten (10) days after installation of said towing system on his vehicle.

The owner is responsible for all normal and preventative maintenance described in the Owner's Manual.

If any defect occurs which the owner believes is covered by this warranty within said five (5) year period, the owner shall contact PULLIAM immediately, either in writing or by telephone call, Attention Customer Service Department. The owner will be instructed to return the hitch at his expense either to an authorized PullRite dealer or to PULLIAM to repair or replace any parts necessary to correct defects in material or workmanship.

Repair or replacement shall be at the sole option of PULLIAM and shall be completed by or on behalf of PULLIAM free of charge for materials and labor.

This warranty gives you specific legal rights, and you may also have other right's which vary from state to state.

THIS WARRANTY SPECIFICALLY *EXCLUDES* EACH OF THE FOLLOWING:

1. Defects in the product resulting from misuse, neglect, accident, loading beyond the vehicle's capacity, failure to comply with instructions contained in the Owner's Manual or unauthorized repairs, replacements, alterations or modifications. "Unauthorized repair, replacements, alterations" are those made without PULLIAM'S prior knowledge and consent.
2. Any incidental or consequential damage including, but not limited to, loss of use of the vehicle, towing charges, vehicle rental, loss of time, inconvenience, travel, gasoline, lodging and telephone expenses, loss of revenue and damages on account of personal injury and property damage. (Some states do not allow the exclusion or limitation of incidental or consequential damages, so these limitations may not apply to you).
3. Repairs or replacements of defects in any PullRite towing system, or part thereof, installed on any vehicle which has been rented, leased or used for any commercial purpose.
4. Any representation, warranty of undertaking made by any dealer or third party beyond the scope of the warranty herein expressed.
5. Any problem resulting in normal deterioration due to wear or exposure.

TO THE EXTENT PERMITTED BY LAW, IMPLIED WARRANTIES OF MERCHANTABILITY AND FITNESS FOR A PARTICULAR PURPOSE ARE LIMITED IN DURATION TO FIVE YEARS FROM THE DATE OF INSTALLATION ON THE FIRST OWNER'S VEHICLE. (SOME STATES, HOWEVER, DO NOT ALLOW LIMITATIONS AS TO DURATION OF IMPLIED WARRANTY, SO THOSE LIMITATIONS MAY NOT APPLY TO YOU)



Product Warranty Registration

As an owner of a PullRite product, you must register your product to be considered for warranty coverage. See Owners Manual for further details.

Please note, that you can also register online at www.pullrite.com/warranty.htm.

Name: _____

Address: _____

City: _____ State: _____ Zip: _____

Email Address: _____

Phone (optional): _____

Purchase Price: _____ Date of Purchase: _____

Dealer's Name: _____

Dealer's Address: _____

Dealer's City: _____ Dealer's State: _____ Dealer's Zip: _____

Dealer's Phone: _____

Model Purchased: _____

Vehicle Make: _____ Vehicle Model: _____ Vehicle Year: _____

Vehicle Year: _____ Vehicle Cab Style: _____ Vehicle Bed Length: _____

Did you receive an Owners Manual from the Dealer? Yes / No

What influenced you to buy your hitch? _____

Comments:



MANUFACTURED BY:

PULLIAM ENTERPRISES, INC.
13790 East Jefferson Blvd.
Mishawaka, IN 46545
(574) 259-1520 • (800) 443-2307
info@pullrite.com • www.pullrite.com